

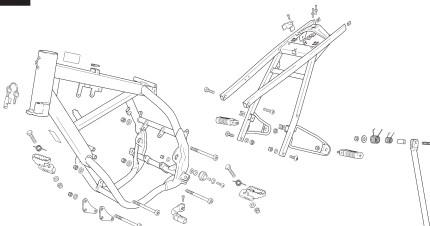

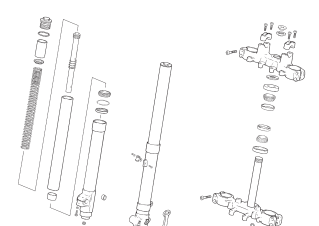
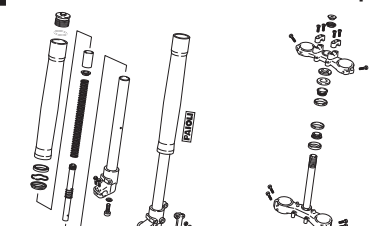
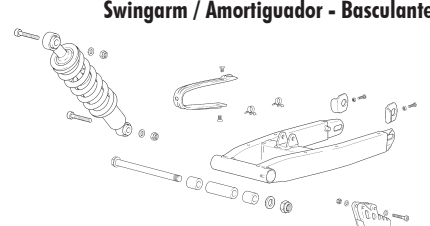
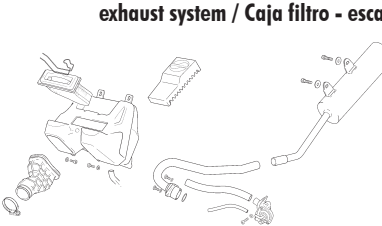
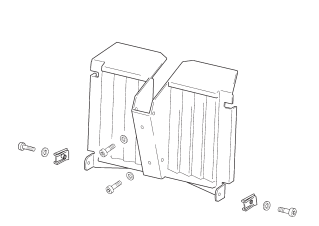
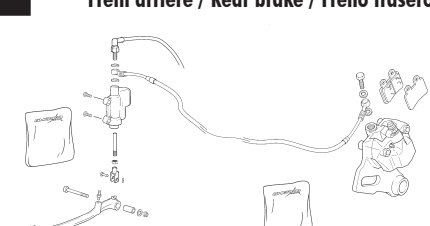
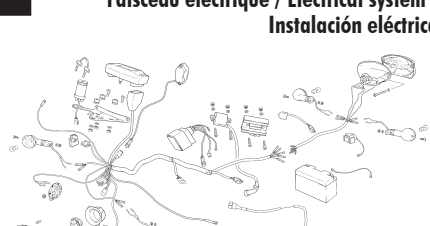

<p>1 Cadre / Frame / Chasis</p>  <p>pag. 1</p>	<p>2 Fourche / Fork / Horquilla</p>  <p>pag. 2</p>	<p>3 Fourche / Fork / Horquilla</p>  <p>pag. 3</p>
<p>4 Amortisseur - Bras oscillant / Rear Shock - Swingarm / Amortiguador - Basculante</p>  <p>pag. 4</p>	<p>5 Boite filtre - echapement / Air filter box - exhaust system / Caja filtro - escape</p>  <p>pag. 5</p>	<p>6 Radiateur / Radiator / Radiador</p>  <p>pag. 6</p>
<p>7 Frein arriere / Rear brake / Freno trasero</p>  <p>pag. 7</p>	<p>8 Faisceau électrique / Electrical system / Instalación eléctrica</p>  <p>pag. 8 - 9</p>	<p>9 Roue avant / Front wheel / Rueda delantera</p>  <p>pag. 10</p>
<p>10 Roue arriere / Rear wheel / Rueda trasera</p>  <p>pag. 11</p>	<p>11 Guidon / Handlebar / Manillar</p>  <p>pag. 12</p>	<p>12 Plastiques / Plastics / Plásticos</p>  <p>pag. 13 - 14</p>
<p>13 Adhesif / Sticker / Adhesivo</p>  <p>pag. 15</p>	<p>14 Cylindre / Cylinder / Cilindro</p>  <p>pag. 16</p>	<p>15 Villebrequin assemble / Crankshaft assembly / Cigüeñal biela</p>  <p>pag. 17</p>

16 Soupape / Valve / Válvula

pag. 18

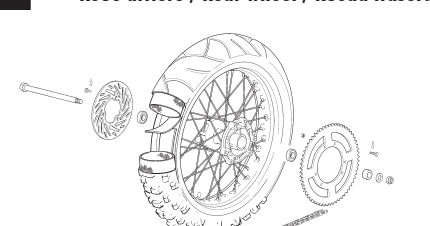
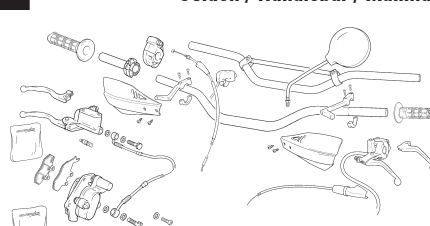
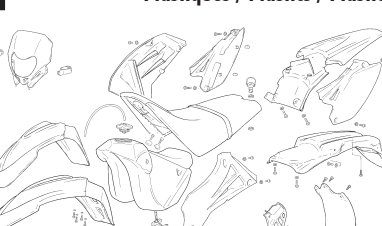
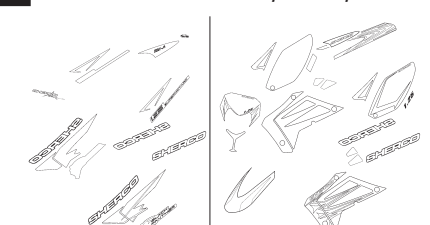
17 Systeme distribution / Distribution system / Sistema distribución

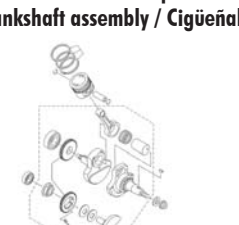
pag. 19

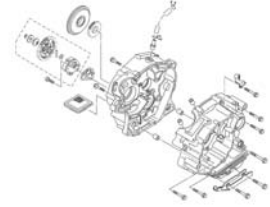
18 Carter centraux / Central crankcase / Carter central

pag. 20

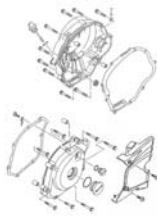
19 Carter latreaux / Lateral crankcase / Carter lateral

pag. 21

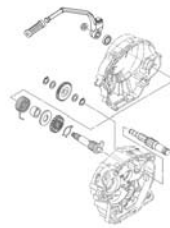
20 Systeme demarreur / Start system / Sistema arranque

pag. 22

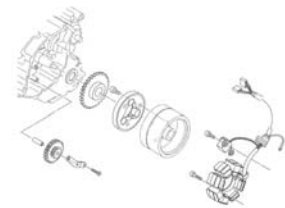
21 Ensemble allumage / Ignition system / Sistema de encendido

pag. 23

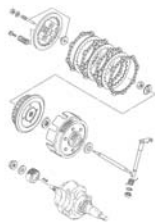
22 Embrayage / Clutch / Embrague

pag. 24

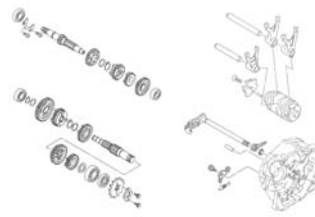
23 Transmission / Transmission / Transmisión

pag. 25 - 26

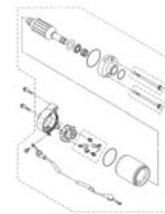
24 Demarreur electrique / Electrical starter / Arranque eléctrico

pag. 27

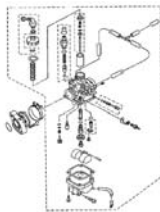
25 Carburateur / Carburator / Carburador

pag. 28

Cadre / Frame / Chasis

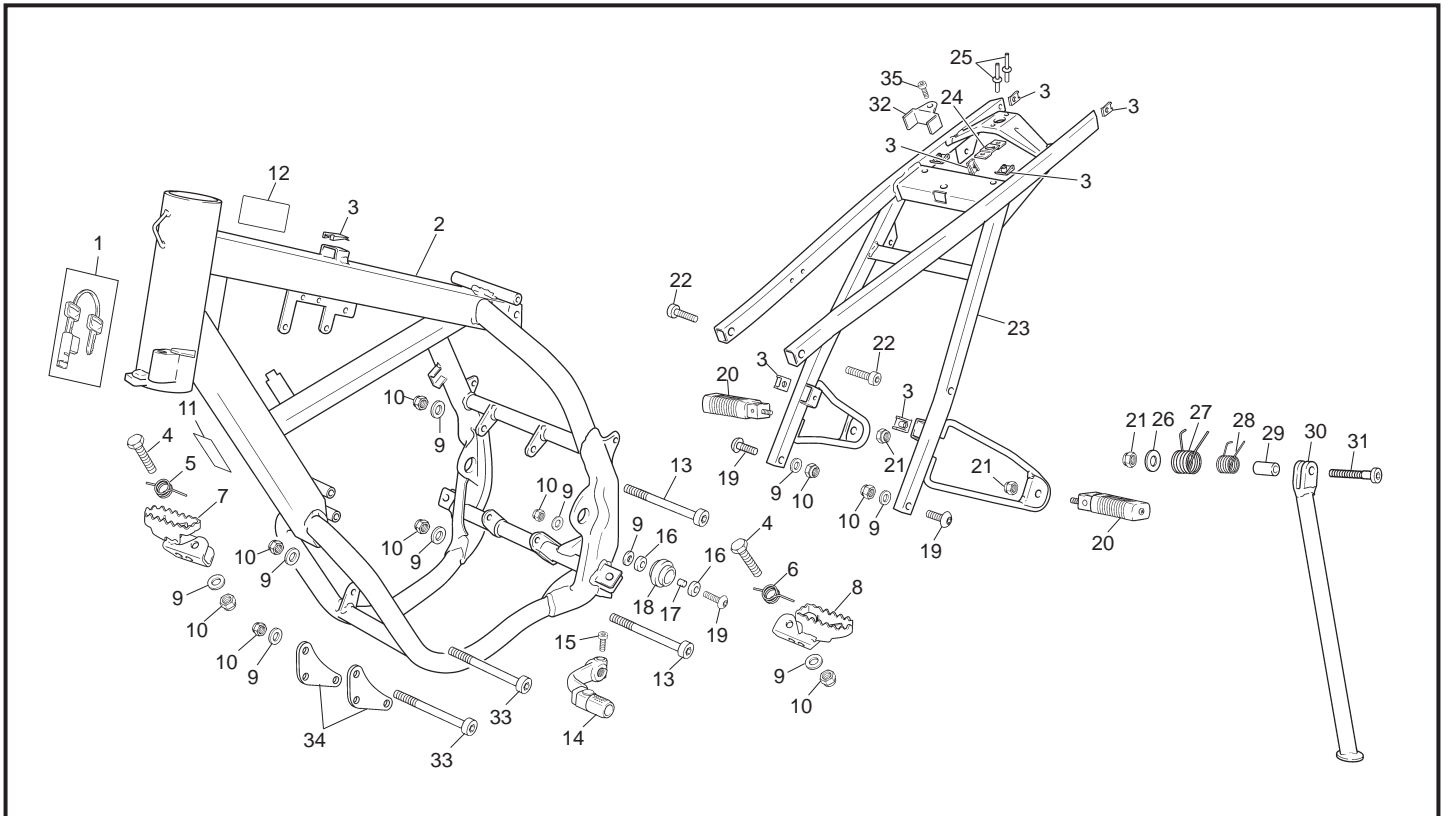

POS.	125 SM	125 END	FRANÇAIS	ENGLISH	ESPAÑOL
1	H173	H173	ANTIVOL DIRECTION END 125	ANTIVOL DIRECTION END 125	ANTIRROBO DIRECCIÓN END 125
2	1438	1438	CADRE PEINT 125 08	PEINT FRAME 125 08	CHASIS PINTADO 125 08
3	M308	M308	ECROU CLIP M6	NUT CLIP M6	TUERCA CLIP M6
4	C422	C422	SCREW 8 X 45	VIS HEXAG 8 X 45	TORNILLO 8 X 45
5	H201	H201	RESSORT CALE PIED DROIT	RIGHT FOOTREST SPRING	MUELLE ESTRIBO DERECHO
6	H202	H202	RIGHT FOOTREST SPRING	RESSORT CALE PIED GAUCHE	MUELLE ESTRIBO IZQUIERDO
7	1439	1439	CALE PIED DROIT	RIGHT FOOTREST	ESTRIBO DERECHO
8	H174	H174	CALE PIED GAUCHE	LEFT FOOTREST	ESTRIBO IZQUIERDO
9	C430	C430	RONDELLE M8	WASHER M8	ARANDELA M8
10	M305	M305	ECROU NYLSTOP M8	NUT NYLSTOP M8	TUERCA NYLSTOP M8
11	1452	1452	PLAQUE CONSTRUCTEUR 125	MANUFACTURE PLATE 125	PLACA CONSTRUCTOR 125 END-SM E3
12	1583	1583	PLAQUE ADE. ANTI MANIPULATION	STICKER ANTI MANIPULATION	PLACA ADH. ANTI MANIPULACIÓN
13	C412	C412	VIS CHC M8 X 100	SCREW M8 X 100	TORNILLO M8 X 100
14	1440	1440	SELECTEUR ALU CURT 125 08	GEAR SELECTOR ALU SHORT 125 08	LEVA SELECTOR ALU CORTO 125 08
15	M252	M252	SCREW CHC 6 X 20	VIS CHC 6 X 20 0084	TORNILLO 6 X 20 DIN 912
16	0577	0577	ROULEMENT 22 X 8 X 7	BEARING 22 X 8 X 7	COJINETE 22 X 8 X 7
17	0556	0556	DOUILLE GALET CHAINE	SPACER CHAIN WEEL	CASQUILLO ROLO CADENA
18	0231	0231	GALET DE CHAINE	ROLER CHAIN GUIDE	ROLO CADENA
19	1028	1028	VIS BHC M8 X 35	SCREW BHC M8 X 35	TORNILLO BHC M8 X 35
20	H186	H186	CALE PIED PASSAGER G/D	PASSENGER FOOTREST	ESTRIBO PASAJERO IZ/DE
21	M304	M304	ECROU NYLSTOP M10	NUT NYLSTOP M10	TUERCA NYLSTOP M10
22	M262	M262	SCREW CHC 8 X 30	VIS CHC 8 X 30 0084	TORNILLO 8 X 30 ALLEN
23	H408	H408	ARRIERE CADRE PEINT 125 08	REAR SUB FRAME PEINT 125 08	SOPORTE SILLÍN PINTADO 125 08
24	0531	0531	PLAQUE DZUS	PLAQUE DZUS	RECEPTACULO DZUS
25	0701	0701	RIVET ZEBRA 3 X 10	RIVET POP DIAM 3 X 10	REMACHE 3 X 10
26	M320	M320	RONDELLE 10 X 30 X 2.5	WASHER 10 X 30 X 2.5	ARANDELA 10 X 30 X2.5 DIN 9021
27	0479	0479	RESSORT BEQUILLE EXT	SPRING STAND EXT	MUELLE CABALLETE EXT
28	0305	0305	RESSORT DE BEQUILLE INT	STAND SPRING INT	MUELLE CABALLETE INT
29	0481	0481	ENTRETOISE RESSORT BEQUILLE	STAND SPACER	CASQUILLO CABALLETE
30	1087	-----	BEQUILLE PEINT 125 08	SIDE STAND PEINT 125 08	CABALLETE PEINT 125 08
30	-----	H409	BEQUILLE PEINT 125 08	SIDE STAND PEINT 125 08	CABALLETE PEINT 125 08
31	0482	0482	VIS BEQUILLE	STAND SCREW	TORNILLO CABALLETE
32	1441	1441	SUPPORT RELAI DE DEMARREUR	RELAY FOR ELECTRIC START SUPPORT	SUPORTE RELE ARRANQUE
33	M266	M266	VIS CHC M8 X 80	SCREW CHC M8 X 80	TORNILLO M8 X 80
34	H338	H338	PATTE SUPPOTRT MOTURE 125	ENGINE HOLDER 125	SOPORTE MOTOR 125
35	M251	M251	VIS CHC M6 X 16	SCREW CHC M6 X 16	TORNILLO M6 X 16

Fourche / Fork / Horquilla

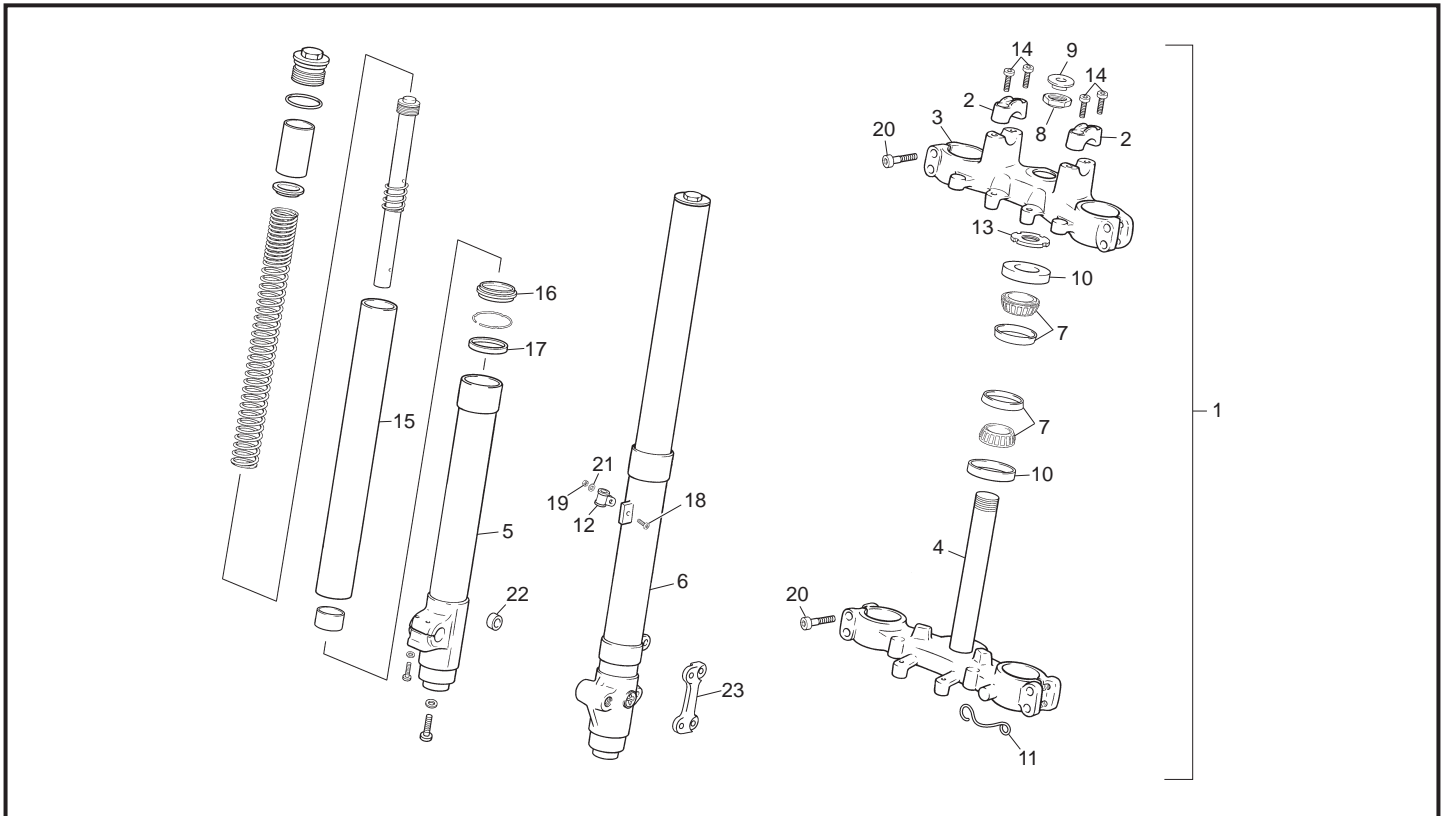

POS.	125 END	FRANÇAIS	ENGLISH	ESPAÑOL
1	H397	FOURCHE PAIOLI 41 END-SM	FRONT SUSPENSION PAIOLI 41	SUSPENSIÓN DEL. PAIOLI 41 ENDSM
2	R340	BRIDE GUIDON SUPERIEURE	TOP HANDLEBAR CLAMP	BRIDA SUPERIOR MANILLAR
3	R341	T SUPERIEUR	UPPER PLATE	PLATINA SUPERIOR
4	R342	T INFERIEUR	BOTTOM PLATE	PLATINA INFERIOR CON EJE
5	1153	BRAS DROIT COMPLET	FORK LEG RIGHT	BOTELLA DERECHA
6	1152	BRAS GAUCHE COMPLET	FORK LEG LEFT	BOTELLA IZQUIERDA
7	H006	KIT ROULEMENT	KIT STEERING BEARING	RODAMIENTO DIRECCIÓN
8	R345	ECROU M25	NUT M25	TUERCA M25
9	R346	BOUCHON DE COLONNE	PLUG	TAPÓN
10	1051	ANNEAU D ETANCHEITE NYLOS	NYLOS RING	JUNTA NYLOS
11	H429	GUIDE DURITE FREIN AV 50-125	GUIDE FRONT BRAKE HOSE 50-125	GUÍA LATIGUILLO FRENO DEL. 50-125
12	1083	COLLIER DURITE NORMA	COLLARD	ABRAZADERA MANGUITOS
13	R347	ECROU M25 ERGOT	STEERING LOCKNUT	ARANDELA APOYO
14	M262	VIS CHC 8X30	SCREW CHC 8X30	TORNILLO 8X30
15	1154	TUBE	HOSE	TUBO
16	R348	PARE POUSSIÈRE	O-RING	GUARDA POLVO HORQUILLA
17	R349	JT SPI	SEAL FORK	RETEN SUSPENSIÓN
18	1030	VIS CHC M5 X 25	SCREW CHC M5 X 25	TORNILLO CHC M5 X 25
19	M355	ECROU NYLSTOP M5	NUT NYLSTOP M5	TUERCA NYLSTOP M5
20	1187	VIS M8X40	SCREW M8X40	TORNILLO M8X40
21	M379	RONDELLE M5	WASHER M5	ARANDELA M5
22	1124	ENTRETOISE DE ROUE	STAND SPACER	CASQUILLO
23	----	DEPORT FIXATOIN	BRAKE CALIPER SUP.	SUPORTE PINZA FRENO

Fourche / Fork / Horquilla

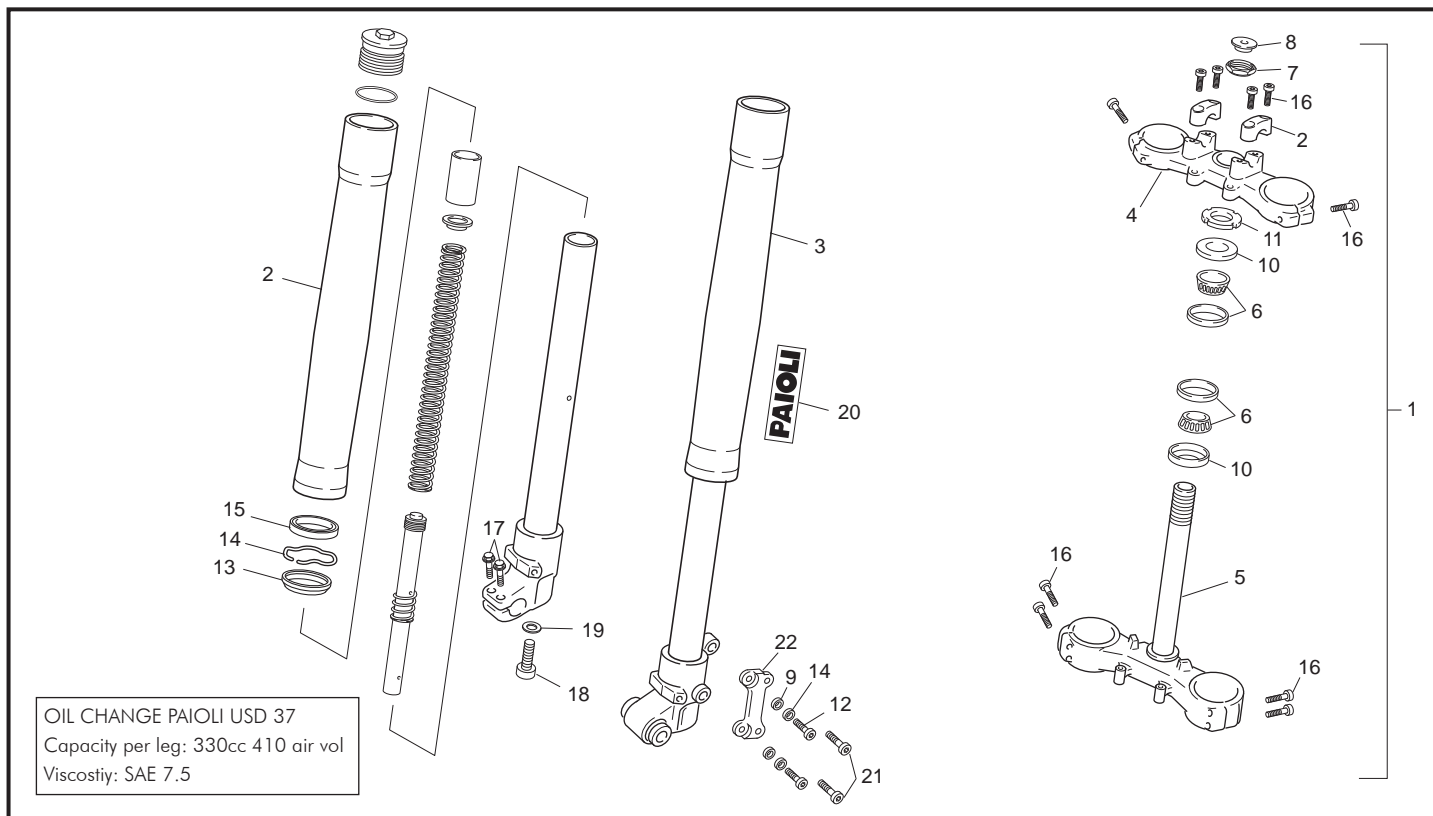

POS.	125 SM	FRANÇAIS	ENGLISH	ESPAÑOL
1	1731	FOURCHE USD 37	FORKS USD 37	HORQUILLA USD 37
2	2179	BRAS DROIT COMPLET	COMPLETE FORK RIGHT LEG	BOTELLA DERECHA COMPLETA
3	2180	BRAS GAUCHE COMPLET	COMPLETE FORK LEFT LEG	BOTELLA IZQUIERDA COMPLETA
4	2181	T SUPÉRIEUR	UPPER CLAMP	PLETINA SUPERIOR
5	2182	T INFÉRIEUR+AXE	BOTTOM CLAMP+SHAFT	PLETINA INFERIOR + EJE
6	H006	KIT ROULEMENT	STEERING SHAFT BEARING SET	KIT RODAMIENTOS DIRECCIÓN
7	R345	ECROU M25X1	NUT M25X1	TUERCA M25X1
8	R346	BOUCHON DE COLONNE	STEERING SHAFT PLUG	TAPÓN EJE DIRECCIÓN
9	1837	ENTRETOISE ÉTRIER ZINGUÉE NOIRE	BLACK CALIPER SPACER	CASQUILLO PINZA ZINGADO NEGRO
10	1051	ANNEAU D'ÉTANCHÉITÉ NYLOS	NYLOS RING	JUNTA NYLOS
11	R347	ECROU À ERGOT M25X1	STEERING LOCK NUT M25X1	TUERCA EJE DIRECCIÓN M25X1
12	M263	VIS CHC M8X40	SCREW CHC M8X40	TORNILLO CHC M8X40
13	2183	PARE POUSSIÈRE	DUST SEAL	GUARDA POLVO
14	1827	ENTRETOISE ÉTRIER ZINGUÉE BLANC	WHITE CALIPER SPACER	CASQUILLO ZINGADO BLANCO PINZA
15	2185	JT SPI	OIL SEAL	RETÉN ACEITE
16	M262	VIS CHC M8X30	SCREW CHC M8X30	TORNILLO CHC M8X30
17	0547	VIS M6X30 THEP	SCREW M6X30 THEP	TORNILLO M6X30 THEP
18	2186	VIS TCCE M10X40	SCREW TCCE M10X40	TORNILLO TCCE M10X40
19	2187	RONDELLE FOURCHE	WASHER FORKS	ARANDELA HORQUILLA
20	2188	ADHÉSIF PAIOLI DROIT/GAUCHE	RIGHT/LEFT PAIOLI STICKER	ADHESIVO PAIOLI DERECHO/IZQ.
21	M260	VIS CHC M8X12	SCREW M8X12	TORNILLO M8X12
22	H192	DÉPORT ÉTRIER SM	BRAKE CALIPER CLAMP SM	SOPORTE PINZA FRENO SM

Amortisseur - Bras oscillant / Rear Shock - Swingarm / Amortiguador - Basculante

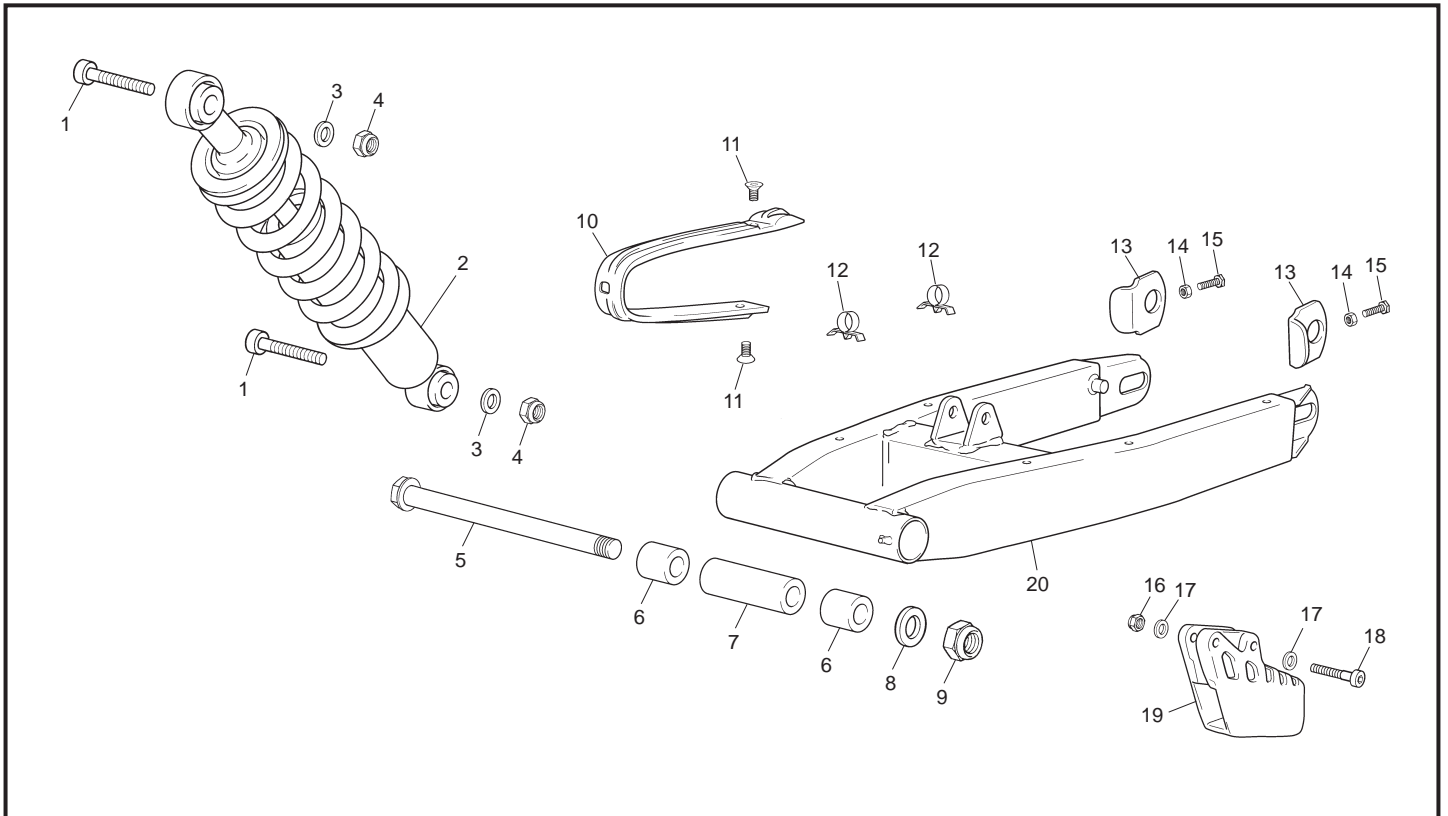

POS.	125 SM	125 END	FRANÇAIS	ENGLISH	ESPAÑOL
1	M259	M259	VIS CHC 10 X 50 0084	SCREW CHC 10 X 50	TORNILLO 10 X 50 ALLEN
2	H396	H396	AMORTISSEUR 50/125	SHOCK ABSORBER 50/125	AMORTIGUADOR 50/125
3	C424	C424	RONDELLE M10	WASHER M10	ARANDELA M10
4	M304	M304	ECROU NYLSTOP M10 0368.10	NUT NYLSTOP M10	TUERCA NYLSTOP M10
5	H127	H127	AXE BRAS OSCILLANT 125 END	SWINGARM AXLE	EJE BASCULANTE
6	H402	H402	SILENT. DE BRAS OSCILLANT 50/125	SILENTBLOC	SILENTBLOC
7	H425	H425	ENTRETOISE BRAS OSCILLANT	SPACER	CASQUILLO
8	C426	C426	RONDELLE M16	WASHER M16	ARANDELA M16
9	C417	C417	ECROU NYLSTOP M16 X 150	NUT NYLSTOP M16 X 150	TUERCA NYLSTOP M16 X 150
10	H065	H065	PATIN CHAINE	CHAIN SLIDER	PATÍN CADENA
11	C433	C433	SCREW FHC M8 X 10	VIS FHC M8 X 10	TORNILLO FHC M8 X 10
12	H273	H273	CLIP DURITE DE FREIN	BRAKE HOSE CLIP	CLIP TUBO FRENO
13	H410	H410	TOLE TENSION CHAINE 50/125	CHAIN TENSIONER 50/125	CHAPA TENSIÓN CADENA 50/125
14	M309	M309	ECROU STANDARD M6 0317	NUT M6	TUERCA M6
15	1027	1027	VIS TH M6 X 60	SCREW TH M6 X 60	TORNILLO TH M6 X 60
16	M306	M306	ECROU NYLSTOP M6 0368.6	NUT NYLSTOP M6	TUERCA NYLSTOP M6
17	C427	C427	RONDELLE M6 X 15	WASHER M6 X 15	ARANDELA M16
18	M256	M256	VIS CHC 6 X 45 0084	SCREW CHC 6 X 45	TORNILLO 6 X 45 ALLEN
19	0296	0296	GUIDE CHAINE	CHAIN GUID	GUÍA CADENA
20	H406	H406	BRAS OSCILLANT PEINT 50/125	SWINGARM PEINT 50/125	BASCULANTE PINTADO 50/125
20	H440	H440	BRAS OSCILLANT PEINT NOIR 50/125	SWINGARM PEINT BLACK 50/125	BASCULANTE PINTADO NEGRO 50/125

Boite filtre - echapement / Air filter box - exhaust system / Caja filtro - escape

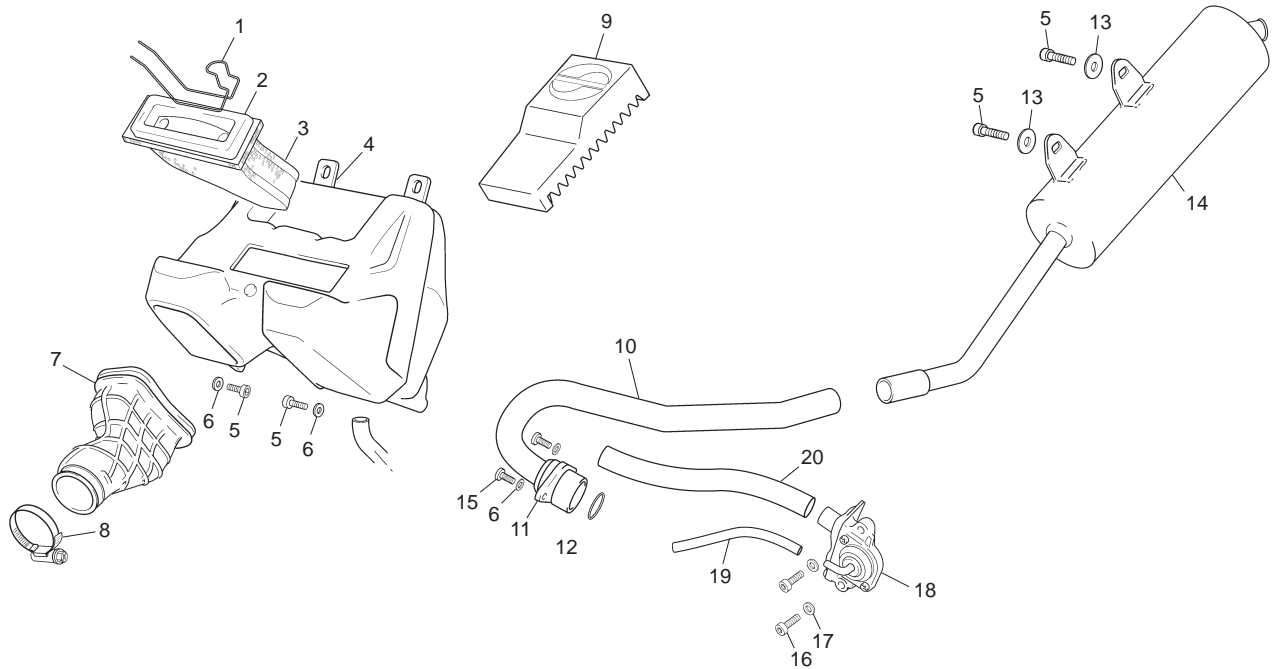

POS.	125 SM	125 END	FRANÇAIS	ENGLISH	ESPAÑOL
1	H430	H430	RESSORT COUVERCLE DE FILTRE	SPRING FILTER COVER	MUELLE TAPA FILTRO
2	H436	H436	COUVERCLE FILTRE AIR 50-125	AIR FILTER BOX COVER 50-125	TAPA FILTRO 50 125 END/SM
3	C108	C108	MOUSSE DE FILTRE	TWIN AIR FOAM	ESPUMA DE FILTRO TWIN AIR
4	H389	H389	BOITE FILTRE AIR 50-125	AIR FILTER BOX 50-125	CAJA DE FILTRO 50-125
5	M251	M251	VIS CHC 6 X 16 0084	SCREW CHC 6 X 16	TORNILLO 6 X 16 DIN 912
6	C427	C427	RONDELLE M6 X 15	WASHER M6 X 15	ARANDELA M16
7	H391	H391	MANCHON FILTRE AIR	AIR FILTER SLEEVE	TUBERA CAJA FILTRO
8	C486	C486	COLLIER SEBRA 32 X 50	HOSE CLAMP 32 X 50	BRIDA TUBERA 32 X 50
9	1236	1236	CALE BATTERIE	BATTERY BLOCK	BLOQUE DE OBRUCIÓN BATERÍA
10	H245	H245	ECHAPPEMENT	EXHAUST	ESCAPE
11	1451	1451	COLLIER ECHAPPEMENT	EXHAUST HOSE	BRIDA ESCAPE
12	0496	0496	JOINT ECHAPPEMENT	EXHAUST GASKET	JUNTA ESCAPE
13	C428	C428	RONDELLE	WASHER	ARANDELA
14	1423	1423	SLIENCIEUX	SILENCER	SILENCIADOR
15	C410	C410	VIS CHC M6 X 25	SCREW M6 X 25	TORNILLO M6 X 25
16	M252	M252	VIS CHC M6 X 20	SCREW M6 X 20	TORNILLO M6 X 20
17	M317	M317	RONDELLE M6 X12	WASHER M6 X 12	ARANDELA M6 X 12
18	1456	1456	VALVE AIS 125	AIS VALVE 125	VÁLVULA AIRE PARALELO 125
19	1036	1036	DURITE COURTE AIS	HOSE AIS	TUBO AIS
20	1037	1037	DURITE LONGUE AIS	HOSE AIS	TUBO AIS

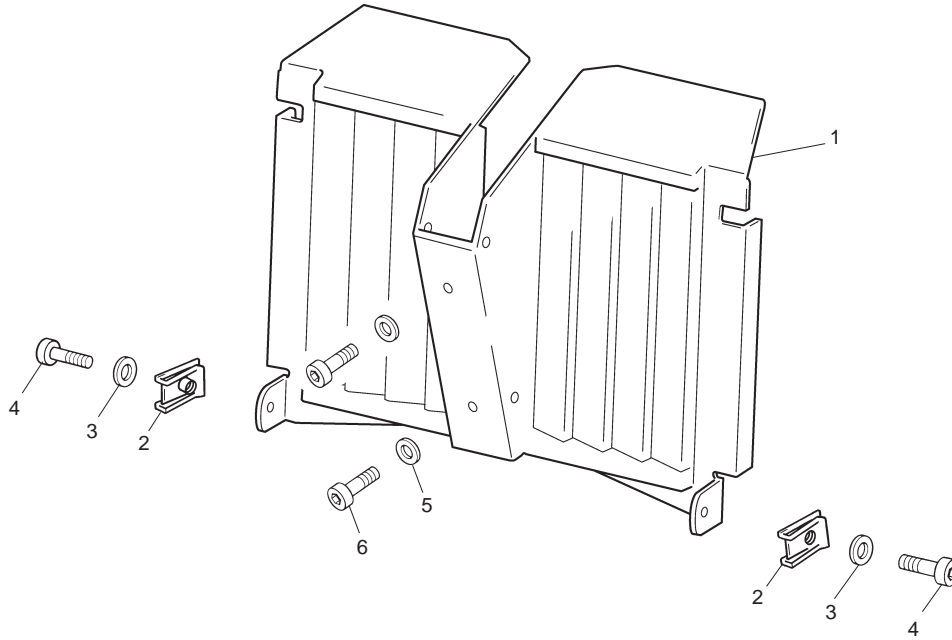
Radiateur / Radiator / Radiador

POS.	125 SM	125 END	FRANÇAIS	ENGLISH	ESPAÑOL
1	1224	1224	DEFLECTEUR	DEFLECTOR	DEFLECTOR
2	M308	M308	CLIP M6	NUT CLIP M6	TUERCA CLIP M6
3	C427	C427	RONDELLE	WASHER	ARANDELA
4	M252	M252	VIS M6 X 20	SCREW M6 X 20	TORNILLO M6 X 20
5	C428	C428	RONDELLE NOIR M6 X 20	WASHER BLACK M6 X 20	ARANDELA M6 X 20
6	C432	C432	VIS NOIR M6 X 16	SCREW BLACK M6 X 16	TORNILLO M6 X 16

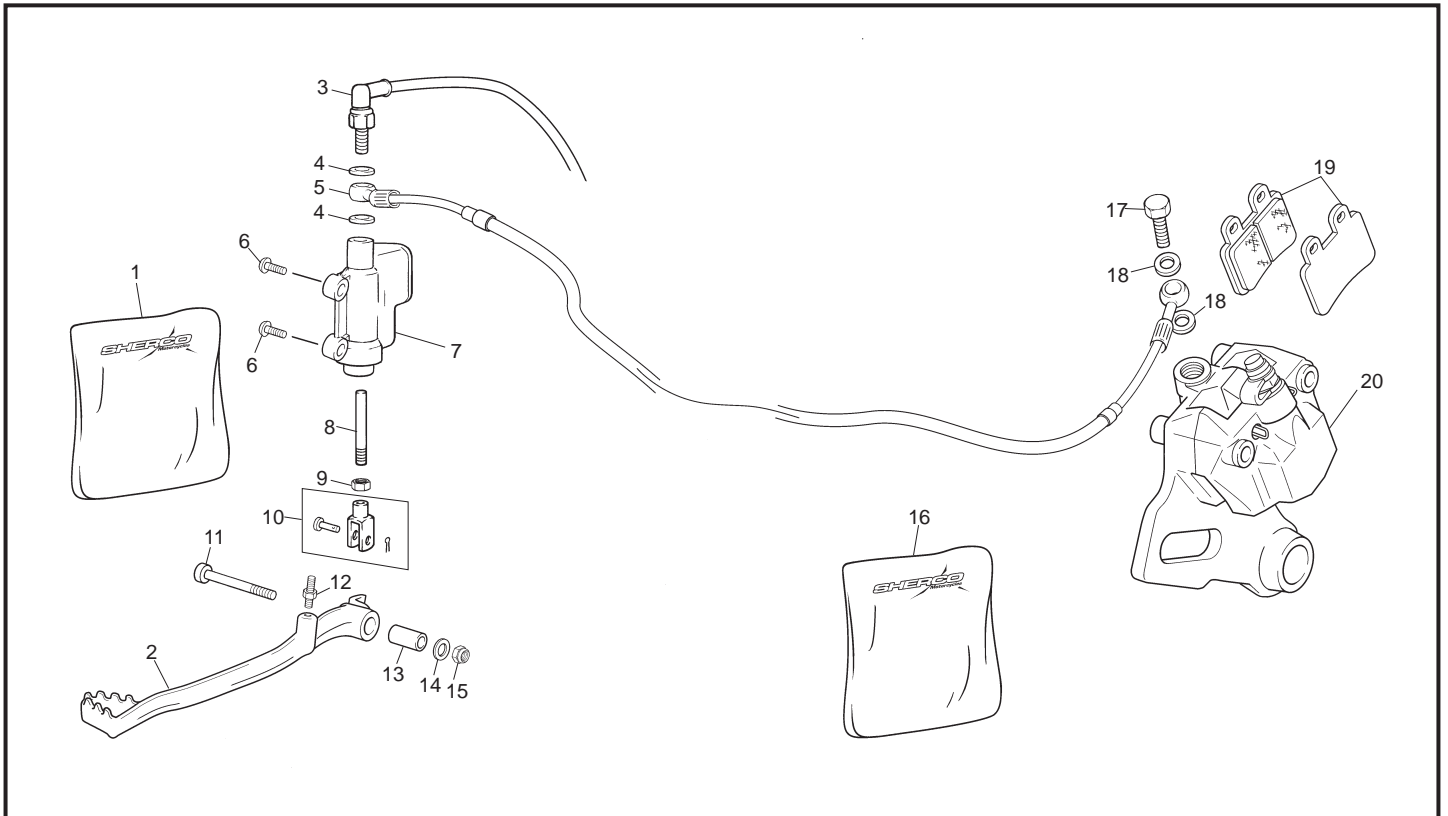
Frein arriere / Rear brake / Freno trasero

POS.	125 SM	125 END	FRANÇAIS	ENGLISH	ESPAÑOL
1	1156	1156	KIT REP. ETRIER AV 50-125	REPAIR KIT FRONT CALIPER	KIT REP. PINZA 50-125
2	H411	H411	PEDALE FREIN ALU 50/125	REAR BRAKE PEDAL	PEDAL DE FRENO TRASERO
3	0625	0625	INTERUPTEUR FREIN	BRAKE ELEC. CONT.	INTERRUPTOR FRENO
4	R074	R074	RONDELLE BANJO	ALUMINIUM SEAL	ARANDELA BANJO
5	1158	1158	DURITE FREIN AR	REAR BRAKE HOSE	LATIGUILLO FRENO
6	M283	M283	VIS BHC 6 X 16 1093	SCREW BHC 6 X 16	TORNILLO 6 X 16 ULS
7	1157	1157	MAITRE CYLINDRE AR	REAR MASTER CYLINDER	BOMBA FRENO TRASERO
8	0374	0374	TIGE FREIN AR	REAR BRAKE PUSHROD	VARILLA FRENO TRAS
9	M309	M309	ECROU STANDARD M6 0317	NUT M6	TUERCA M6
10	H122	H122	CHAPE DE FREIN	BREAK PEDALE BALANCE	HORQUILLA PEDALE FRENO
11	C406	C406	VIS CHC M8 X 50	SCREWCHC M8 X 50	TORNILLO CHC M8 X 50
12	1049	1049	VIS BUTEE DE FREIN AR 50 END SM	REAR BREAK SCREW 50 END SM	TORNILLO
13	H123	H123	ENTRETOISE PEDALE FREIN	REAR BRAKE PEDAL BRACE	CASQUILLO PEDAL FRENO
14	C430	C430	RONDELLE M8	WASHER M8	ARANDELA M8
15	M305	M305	ECROU NYLSTOP M8 0368.8	NUT NYLSTOP M8	TUERCA NYLSTOP M8
16	1155	1155	KIT REPARTION ETRIER AR	REPAIR KIT CALIPER	KIT REP. PINZA
17	R059	R059	VIS RACCORD	BANJO SCREW	TORNILLO RACORD ULS
18	R074	R074	JOINT	BANJO SEAL	ARANDELA BANJO
19	1160	1160	PLAQUETTES FREIN AR	PADS REAR BRAKE	JUEGO PASTILLAS TRASERO
20	1159	1159	ETRIER FREIN AR.	RAER CALIPER	PINZA FRENO

Faisceau électrique / Electrical system / Instalación eléctrica

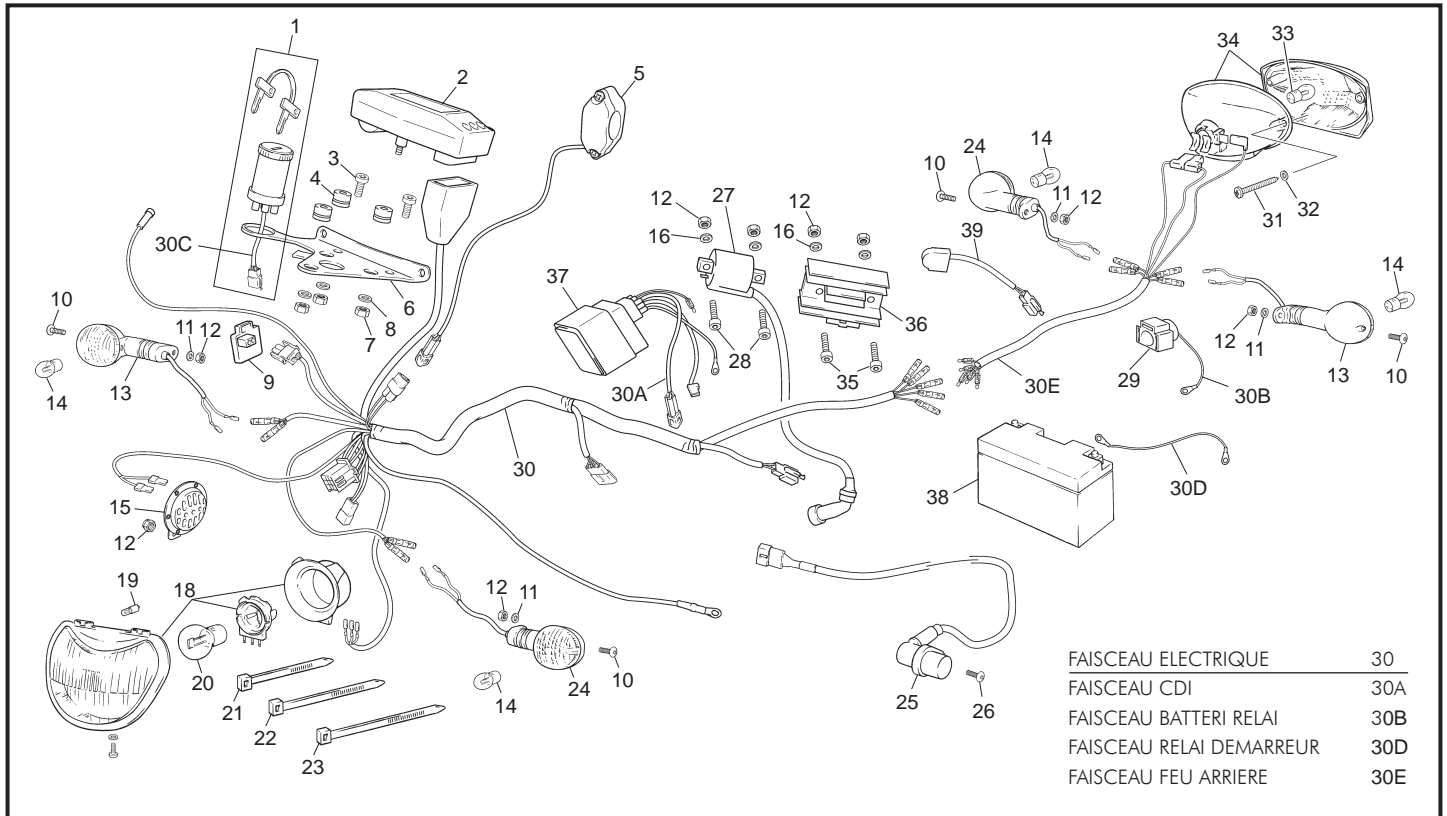

POS.	125 SM	125 END	FRANÇAIS	ENGLISH	ESPAÑOL
1	2313	2313	BLOC CLE DEMARRAGE END 125	BLOC KEY STARTER END 125	BLOC LLAVE ARRANQUE END 125
2	1723	1723	COMPTEUR DE VITESSE END 125	SPEEDOMETER END 125	VELOCIMETRO END 125
3	C409	C409	VIS CHC M6 X 10	SCREW CHC M6 X 10	TORNILLO M6 X 10 CHC
4	0582	0582	SILENBLOC COMPTEUR	SILENBLOC COMPTEUR	SILENBLOC COMPTEUR
6	2383	2383	SUPPORT COMPTEUR VITESSE END	SPEED METER HOLDER END	SOPORTE VELOCÍMETRO END
7	M379	M379	ECROU NYLSTOP M6	NUT NYLSTOP M6	TUERCA NYLSTOP M6
8	0576	0576	RONDELLE M6 X 15	WASHER M6 X 15	ARANDELA M16
9	0364	0364	CENTRALE CLIGNOT	INDICATIVE LIGHT SYSTEM	CENTRAL INTERMITENCIA
10	M283	M283	VIS BHC 6 X 16	SCREW BHC 6 X 16	TORNILLO 6 X 16 ULS
11	C427	C427	RONDELLE M6 X 15	WASHER M6 X 15	ARANDELA M16
12	M306	M306	ECROU NYLSTOP M6	NUT NYLSTOP M6	TUERCA NYLSTOP M6
13	H166	H166	CLIGNOTEUR AVD/ARG END	TURN LIGHT FRONT/RIGHT - REAR/LEFT	INTERMITENTE DEL./DER./TRAS./IZQ
14	C405	C405	AMPOULE CLIGNO 10W 12V	LGHT BULB 10W 12V	BOMBILLA INTERMITENTES 10W 12V
15	0447	0447	CLAXON	HORN	CLAXON
16	M317	M317	RONDELLE 6 X12	WASHER X 6	ARANDELA 6 DIN 125 A
17	M251	M251	VIS CHC 6 X 16	SCREW CHC 6 X 16	TORNILLO 6 X 16 DIN 912
18	0361	0361	OPTIQUE PHARE	FRONT LIGHT OPTICAL	FARO DEL
19	0697	0697	AMPOULE VEILLE 4W 12V	RUNNING LIGHT BULB 4W 12V	BOMBILLA POSICIÓN 4W 12V
20	C403	C403	AMPO. PHARE HOMOL. 35/35W 12V	HEADLIGHT BULB 35/35W 12V	BOMBILLA FARO 35/35W 12V
21	M331	M331	COLLIER RISLAN 100X2.5	ZIP TIE100X2.5	ABRAZADERA 100X2.5
22	M330	M330	COLLIER RISLAN 178X4.8	ZIP TIE 178X4.8	ABRAZADERA 178X4.8
23	C441	C441	COLLIER RISLAN 208X4.8	ZIP TIE 208X4.8	ABRAZADERA 208X4.8
24	H167	H167	CLIGNOTEUR AVG/ARD	TURN LIGHT/Front LEFT - REAR RIGHT	INTERMITENTES DEL./IZQ. TRAS./DRE.
25	0372	0372	CAPTEUR TOURS	REVOLUTION SENSOR	SENSOR REVOLUCIÓN
26	0656	0656	VIS THEP 6X16	SCREW THEP 6X16	TORNILLO THEP 6X16
27	1449	1449	BOBINE HT 125	COIL HT 125	BOBINA HT 125
28	M251	M251	VIS CHC M6X20	SCREW CHC 6X20	TORNILLO 6X20
29	1447	1447	RELI DE DEMARREUR	RELAY FOR ELECTRIC	RELÉ ARRANQUE
30	2124	2124	FAISCEAU ELECTRIQUE	ELECTRIC CABLE	INSTALACIÓN ELÉCTRICA
31	0657	0657	VIS M4 X 40 CRUCIFORME	SCREW M4 X 40	TOR. M4 X 40 CRUCIFORME DIN 7881
32	0656	0656	RONDELLE M4	WASHER M4	ARANDELA M4
33	H252	H252	AMPOULE FEU AR	TAIL LIGHT BULB	BOMBILLA LUZ TRASERA
34	0362	0362	FEU AR.	REAR LIGHT	FARO TRAS
35	M235	M235	VIS CHC M6 X 35	SCREW CHC M6 X 35	TORNILLO CHC M6 X 35

Faisceau électrique / Electrical system / Instalación eléctrica

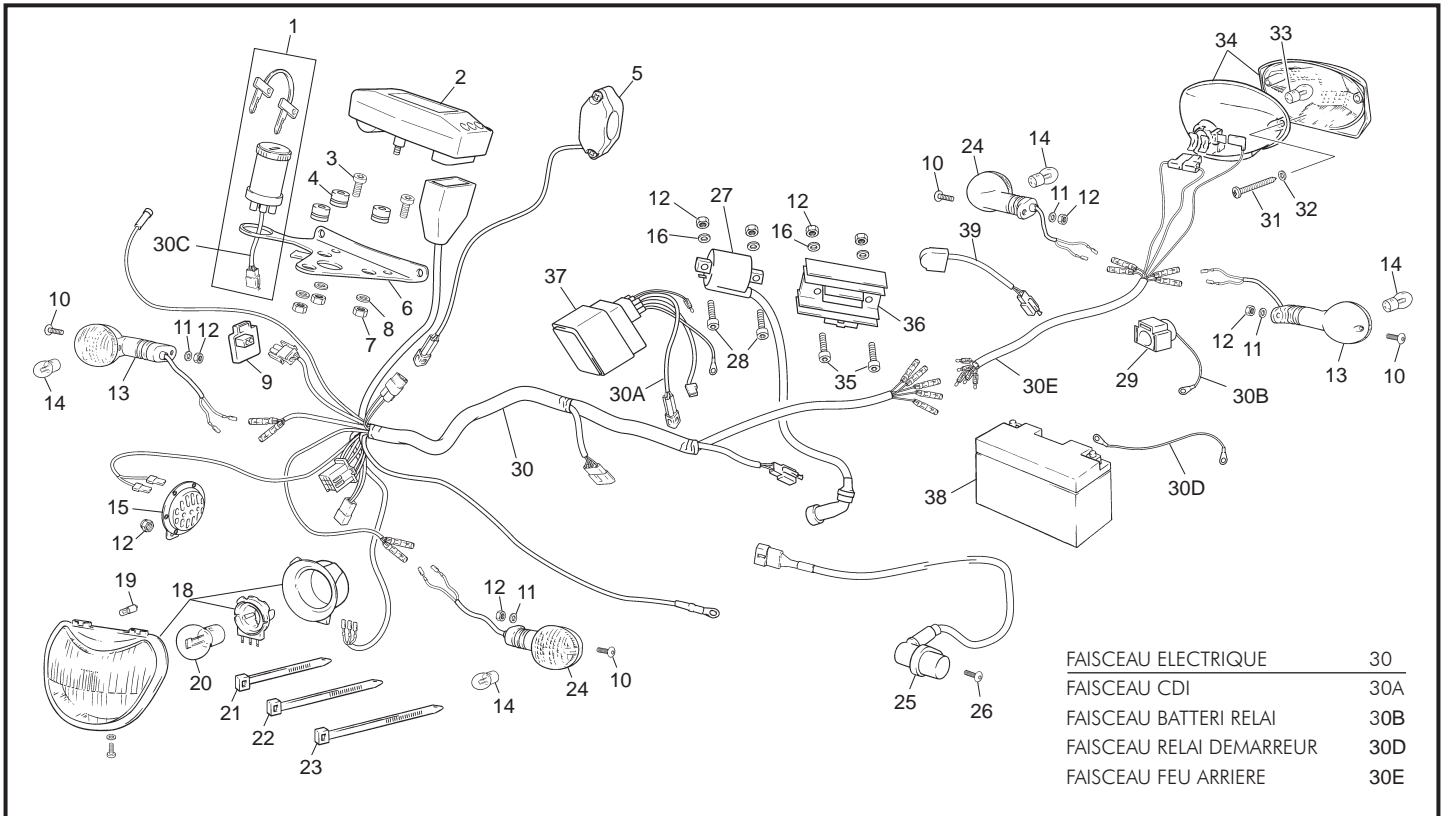

POS.	125 SM	125 END	FRANÇAIS	ENGLISH	ESPAÑOL
36	1458	1458	REGULATEUR 125	REGULATOR 125	REGULATOR 125
37	1459	1459	CDI 125 4T 8 POLES	CDI 125 4T 8 CONECT.	CDI 125 4T 8 POLOS
38	1442	1442	BATTERIE SLA 12-4 AMP	RELAY FOR ELECTRIC	BATERÍA SLA 12-4 AMP
39	1460	1460	BOITIER THERMO SWITCH	THERMO SWITCH BOX	CAJA DE THERMO SWITCH

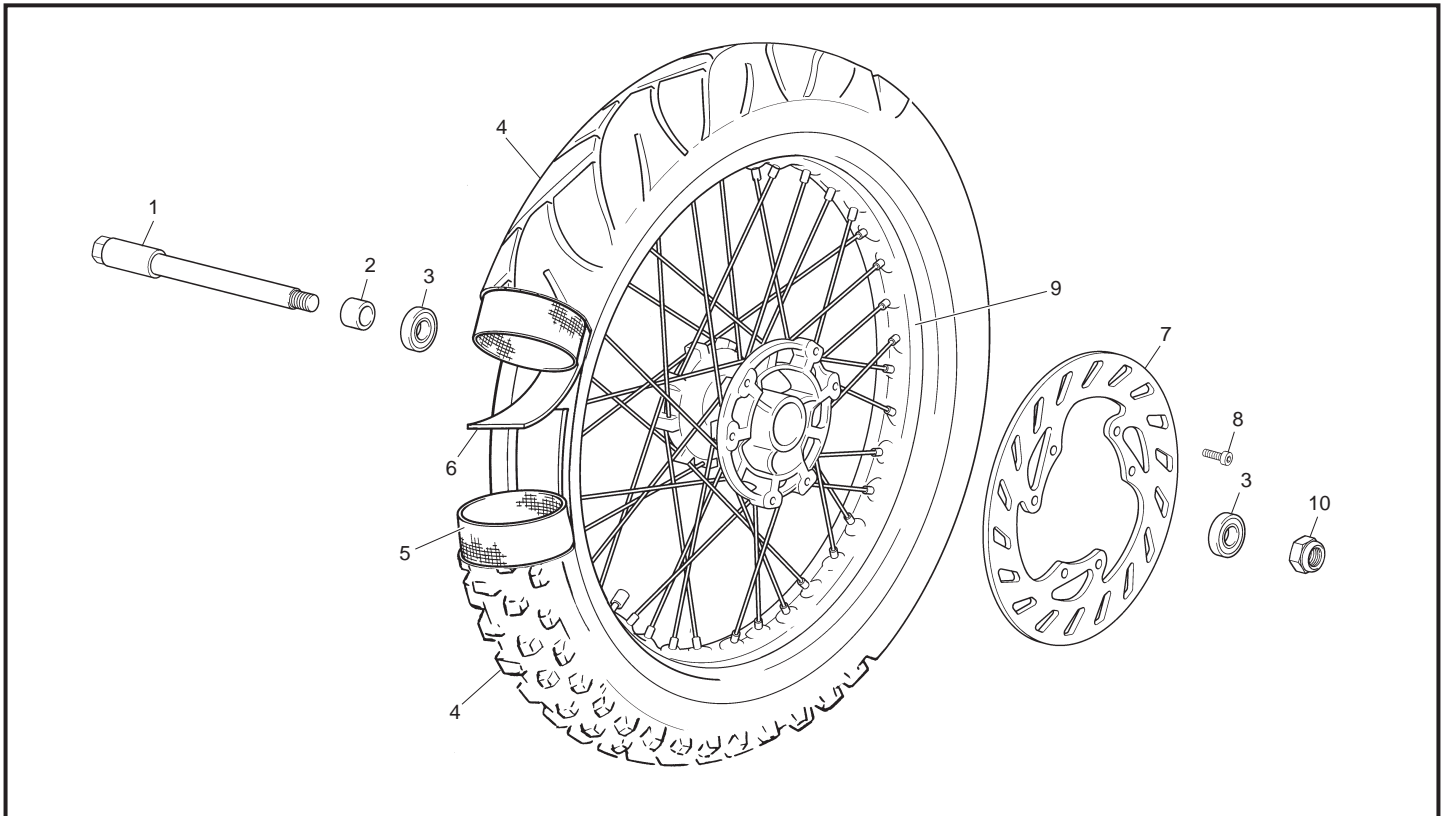
Roue avant / Front wheel / Rueda delantera

POS.	125 SM	125 END	FRANÇAIS	ENGLISH	ESPAÑOL
1	H400	H400	AXE ROUE AVANT 50/125	FRONT WHEEL AXLE	EJE RUEDA DEL
1	-----	1710	AXE ROUE AVANT 50/125	FRONT WHEEL AXLE	EJE RUEDA DEL
2	H404	H404	ENTRETOISE ROUE AVANT 50/125	FRONT WHEEL SPACER	CASQUILLO RUEDA DEL.
2	-----	1711	ENTRETOISE ROUE AVANT 50/125	FRONT WHEEL SPACER	CASQUILLO RUEDA DEL.
3	R360	R360	ROULEMENT NOYEU AV.	HUB BEARING	RODAMIENTO BUJE
4	H080	-----	PNEU AV. SM 100/80.17	FRONT TYRE SM 100/80.17	NEUMÁTICO DEL. SM 100/80.17
4	-----	H084	PNEU AV. END 90/90.21	FRONT TYRE END 90/90.21	NEUMÁTICO DEL. END 90/90.21
5	H081	-----	CHAMBRE AV. SM 300 X 17	FRONT INNER TUBE SM 300 X 17	CAMARA DELANTERA SM 300 X 17
5	-----	H077	CHAMBRE AV. END 300 X 21	FRONT INNER TUBE END 300 X 21	CAMARA DEL. END 300 X 21
6	H078	H078	CORDON JANTE AV. TRAIL	FRONT RIM RUBBER BAND	BANDA LLANTA DEL. TRAIL
7	-----	1734	DISQUE AVANT 50/125 END 260MM	BRAKE DISK 50/125 END 06	DISCO DELANTERO 50/125 END 06
7	1733	-----	DISQUE AVANT SM 50/125 300MM	BRAKE DISK SM 50/125 06	DISCO DEL. SM 50/125 06
8	H429	H429	VIS CHC TETEBA. 6 X 20	SCREW CHC	TORNILLO CHC
9	1043	-----	ROUE AV. SM NOIR	FRONT WHEEL SM BLACK	RUEDA DEL. SM NEGRA
9	1750	2122	ROUE AV 50 END USD TITANE	FRONT WHEEL 50 END USD TITANIUM	RUEDA DEL 50 END USD TITANE
9	-----	1240	ROUE AV. END NOIR 08	FRONT WHEEL END BLACK 08	RUEDA DEL. END NEGRA 08
10	0444	0444	ECROU M12	SCREW M12	TUERCA M12

Roue arriere / Rear wheel / Rueda trasera

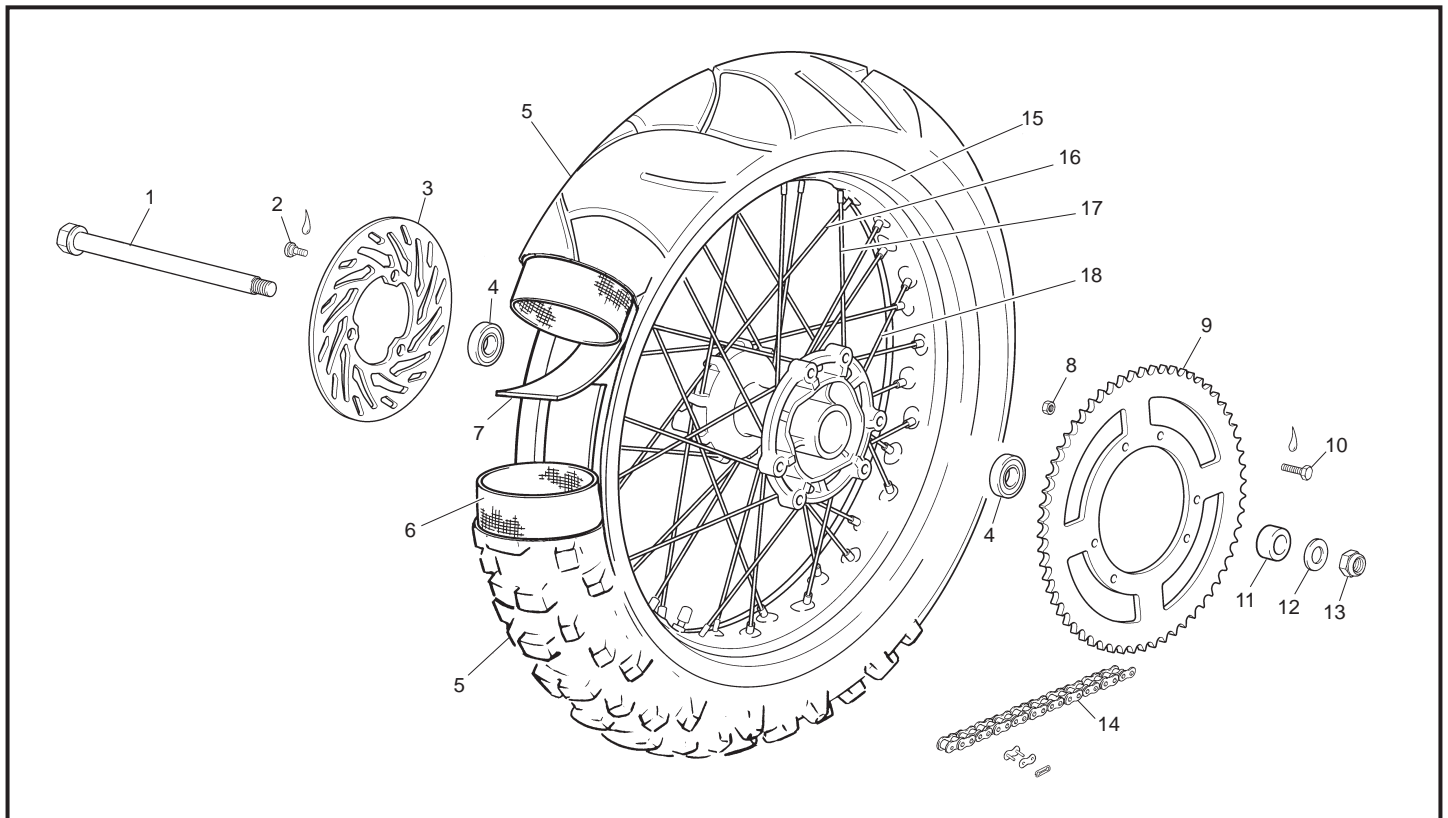

POS.	125 SM	125 END	FRANÇAIS	ENGLISH	ESPAÑOL
1	H401	H401	AXE ROUE ARRIERE 50/125 06	REAR AXLE	EJE RUEDA TRAS.
2	0452	0452	VIS SPECIALE DISQUE	SCEW SPECIAL BRAKE DISC	TORNILLO ESPECIAL DISCO FRENO
3	1735	1735	DISQUE FREIN ARR 50/125 06	BRAKE DISK REAR 50/125 06	DISCO FRENO TRAS. 50/125 06
4	R362	R362	ROULEMENT MOYEU AR	HUB DEARING	RODAMIENTO BUJE
5	H083	-----	PNEU ARR SM 130/70.17	REAR TYRE SM 130/70.17	NEUMÁTICO TRAS. SM 130/70.17
5	-----	H086	PNEU ARR END 110/80.18	REAR TYRE SM 110/80.18	NEUMÁTICO TRASERO END 110/80.18
6	H082	-----	CHAMBRE AR. SM 400 X 17	REAR INNER TUBE SM 400 X 17	CAMARA TRASERA SM 400 X 17
6	-----	H088	CHAMBRE AR. END 300 X 18	REAR INNER TUBE END 300 X 18	CAMARA TRASERA END 300 X 18
7	H079	H079	CORDON JANTE 17	17 RIM RUBBER BAND	BANDA LLANTA 17
8	M305	M305	ECROU NYLSTOP M8	NUT NYLSTOP M8	TUERCA NYLSTOP M8
9	H349	H349	COURONNE Z47	REAR SPROCKET Z47	CORONA TRASERA Z47
10	C420	C420	VIS HEXAG 8 X 30	SCREW 8 X 30	TORNILLO 8 X 30
11	H403	H403	ENTRETOISE ROUE AR.	FRONT WHEEL SPACER	CASQUILLO RUEDA IZQ.
12	C426	C426	RONDELLE M16	WASHER M16	ARANDELA M16
13	C417	C417	ECROU NYLSTOP M16 X 150	NUT NYLSTOP M16 X 150	TUERCA NYLSTOP M16 X 150
14	1450	1450	CHAINE 130 M	CHAIN 130 Z	CADENA 130 Z
15	1751	-----	ROUE AR 50 SM TITANE	BACK WEEL 50 SM TITANE	RUEDA TRA 50 SM TITANE
15	-----	2123	ROUE AR END 50 TITANE 09	REAR WHEEL 50 END TITANE 09	RUEDA TRA 50 END TITANE 09
16	1664	-----	RAYON 193 X 3,5	SPOKE 193 X 3,5	RADIO 193 X 3,5
17	1665	-----	RAYON 199 X 3,5	SPOKE 199 X 3,5	RADIO 199 X 3,5
18	1666	-----	RAYON 201 X 3,5	SPOKE 201 X 3,5	RADIO 201 X 3,5

Guidon / Handlebar / Manillar

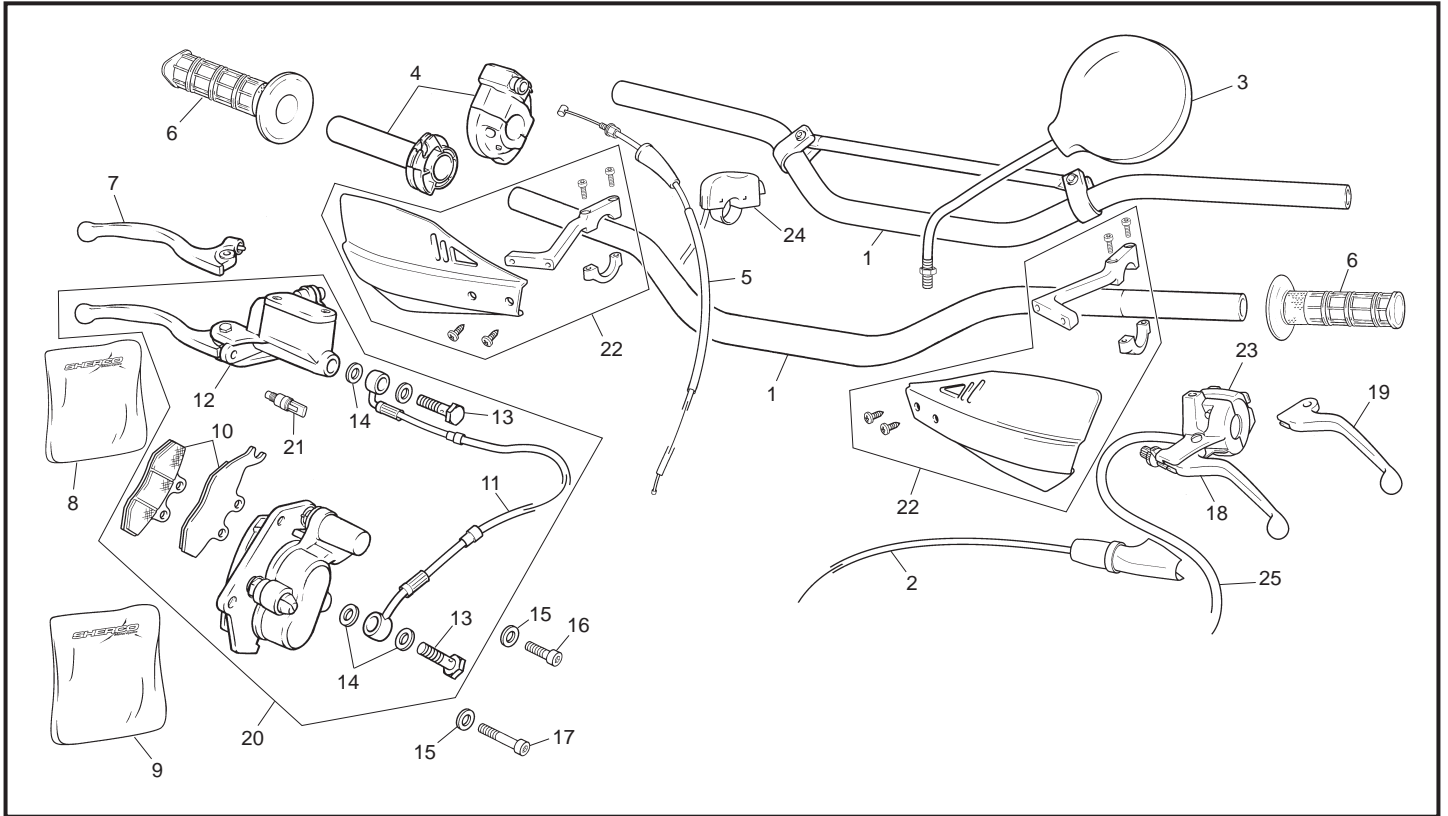

POS.	125 SM	125 END	FRANÇAIS	ENGLISH	ESPAÑOL
1	H210	H208	GUIDON	HANDLEBAR	MANILLAR
2	H140	H140	CABLE EMBRAYAGE 50 END	CLUTCH CABLE ENDURO 50	CABLE EMBRAGUE 50 ENDURO
3	S232	S232	RETROVISEUR	DRIVING MIRROR	RETROVISOR
4	C074	C074	COMMANDE DE GAZ	THROTTLE ASSEMBY	MANDO GAS
5	H139	H139	CABLE DE GAZ	THROTTLE CABLE	CABLE DE GAS
6	H216 (D)-H217(G)	H216 (D)-H217(G)	POIGNETS CAOUTCHOUC (D-G)	HANDLEBAR GRIP (R-L)	PUÑO (DRE. -IZQ.)
7	1188	1188	LEVIER FREIN AVANT	FRONT BRAKE LEVER	MANETA FRENO
8	C648	C648	KIT REPARATION POMPE FREIN	BRAKE MASTER CYLINDER REPAIR KIT	KIT REPA. BOMBA DE FRENO
9	R234	R234	KIT REPARATION ETRIER	BRAKE CALIPER REPAIR KIT	KIT REPA. PINZA DEL.
10	1677	1677	PLAQUETTES FREIN AV PAIRE	FRONT BRAKE PADS (PAIR)	JUEGO PASTILLAS FRENO DEL.
11	R352	R352	DURITE FREIN AV.	FRONT BRAKE HOSE	LATIGUILLO FRENO DELANTERO
12	1196	1196	POMPE COMPLETE 125	MASTER 125	BOMBA COMPLETE 125
13	R059	R059	VIS BANJO	SCREW	TORNILLO BANJO
14	R074	R074	RONDELLE BANJO	WASHER	ARANDELA BANJO
15	C430	C430	RONDELLE M8X16	WASHER M8X16	ARANDELA M8X16
16	C406	C406	VIS M8X50	SCREW M8X50	TORNILLO M8X50
17	C414	C414	VIS M8X35	SCREW M8X35	TORNILLO M8X35
18	1437	1437	COCOTTE EMBRAYAGUE COMPL.	CLUTCH CONTROL COMPLETE	MANDO EMBRAGUE COMPLETO
19	1186	1186	LEVIER EMBRAYAGE	CLUTCH LEVER	MANETA EMBRAGUE
20	H414	H414	GROUPE FREIN AV CPL 50/125 06	FRONT BRAKE SISTEM 50/125 06	CONJUNTO FRENO DEL 50/125 06
21	R354	R354	CONTACTEUR FREIN AV.	FRONT BRAKE LIGHT SWITCH	INTERRUPTOR FRENO DEL.
22	1035	1035	PARE MAINS END NOIR	HAND GUARD BLACK	PARA MANO NEGRO
22	1034	1034	PARE MAINS BLEU	HAND GUARD BLUE	PARA MANO AZUL
23	H431	H431	COMMODO ELECTRIQUE	ELECTRIC COMMANDE 50	CONMUTADOR ELÉCTRICO 50
24	H152	H152	CONTATEUR DEMURREUR	STARTER COMECTOR	STARTER CONTACTOR
25	1524	1524	CABLE STARTER	STARTER CABLE	CABLE ESTÁRTER

Plastiques / Plastics / Plásticos

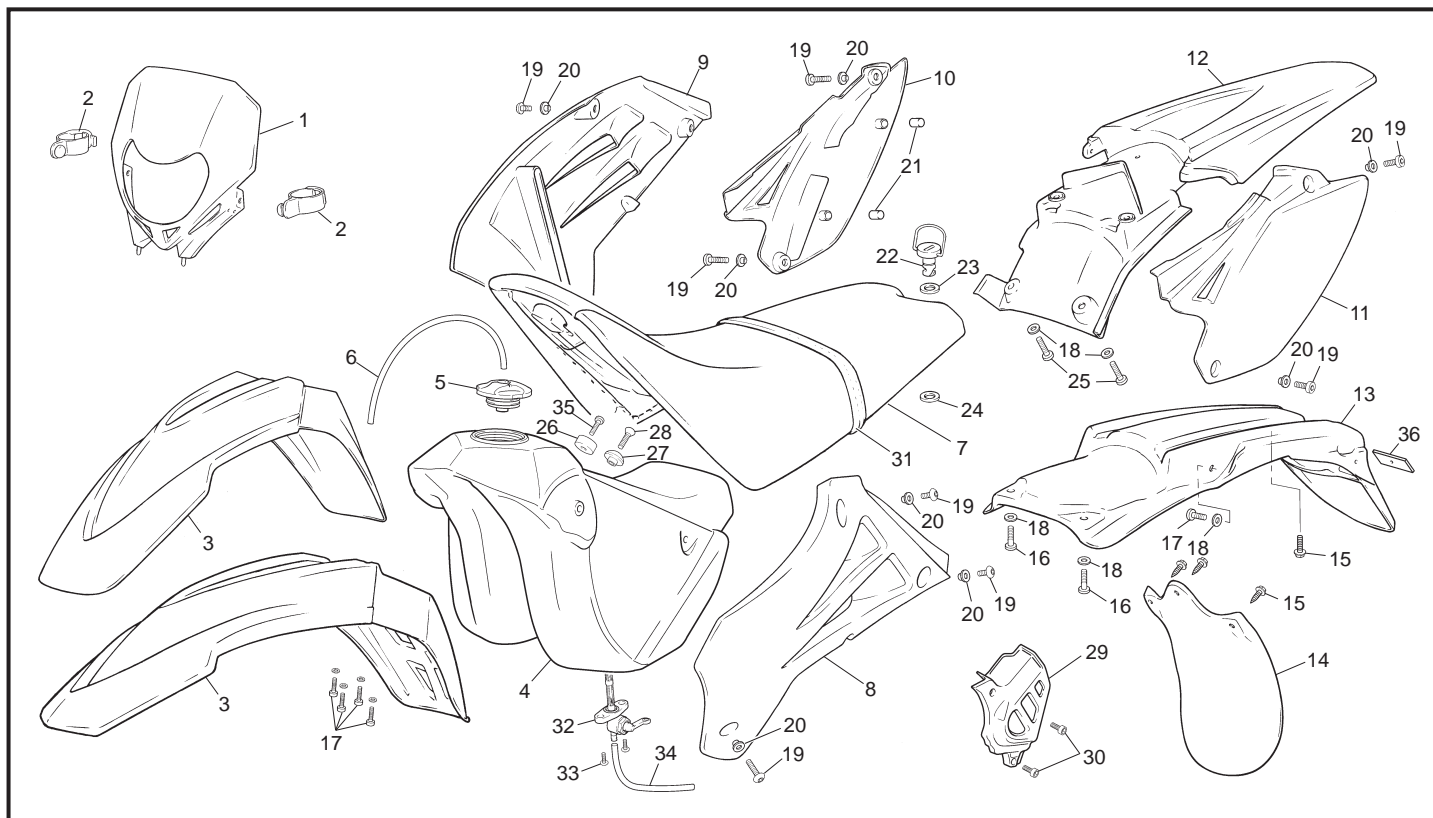

POS.	125 SM	125 END	FRANÇAIS	ENGLISH	ESPAÑOL
1	-----	0250	PLAQUE PHARE BLEU	FRONT LIGHT PLASTIC BLUE	PLACA FARO AZUL
1	S360	-----	PLAQUE PHARE NOIR	FRONT LIGHT PLASTIC BLACK	PLACA FARO NEGRO
1	-----	1517	PLAQUE PHARE BLANCHE	FRONT LIGHT PLASTIC WHITE	PLACA FARO BLANCA
2	H050	H050	ELASTIQUE PLAQUE PHARE	FRONT LIGHT RUBBER BAND	ELÁSTICO PLACA FARO
3	-----	0248	PARE BOUE AVANT BLEU END	FRONT MUDGUARD END BLUE	GUARDABARRO AZUL END
3	S358	-----	PARE BOUE AVANT NOIR SM	FRONT MUDGUARD SM BLACK	GUARDABARRO NEGRO SM
4	H390	H390	RESERVOIR 50-125 06	PETROL TANK 50-125 06	DEPÓSITO 50-125 06
5	H398	H398	BOUCHON ESSENCE PLAT ACERBIS	PETROL CAP	TAPÓN GASOLINA PLANO ACERBIS
6	H040	H040	DURITE BOUCHON ESENCE 5X10X255	PETROL CAP GASKET	JUNTA TAPÓN DE GASOLINA
7	0780	0780	SELLE NOIR	SEAT BLACK	SILLÍN NEGRO
8	-----	1929	OUIE GAUCHE BLEU	RADIATOR SIDE PANEL BLUE	PLACA RADIADOR IZQ. AZUL
8	S362	-----	OUIE GAUCHE SM NOIR	RADIATOR SIDE PANEL SM BLACK	PLACA RADIADOR IZQ. SM NEGRA
9	-----	1928	OUIE DROITE END BLEU	RADIATOR SIDE PANEL R END BLUE	PLACA RADIADOR DER. END AZUL
9	S361	-----	OUIE DROITE SM NOIR	RADIATOR SIDE PANEL R SM BLACK	PLACA RADIADOR DER. SM NEGRA
10	S356	-----	PLAQUE LATERAL DROITE NOIR	SIDE NUMBER PLATE R BLACK	PLACA NO DER. NEGRA
10	-----	1515	PLAQUE LATERAL DROITE BLANCHE	SIDE NUMBER PLATE R WHITE	PLACA NO DER. NEGRO
11	S357	-----	PLAQUE LATERAL GAUCHE NOIR	SIDE NUMBER PLATE L BLACK	PLACA NO IZQ. NEGRA
11	-----	1514	PLAQUE LATERAL GAUCHE BLANCHE	SIDE NUMBER PLATE L WHITE	PLACA NO IZQ. NEGRO
12	S359	-----	PARE BOUE ARRIERE END NIOR	BACK MUDGUARD END BLACK	GUARDABARRO TRAS. END NEGRO
12	-----	1513	PARE BOUE ARRIERE END BLANC	BACK MUDGUARD END WHITE	GUARDABARRO TRA END BLANCO
13	0253	0253	SUPPORT FEU AR END + HOMOL SUP	BACK LIGHT HOLDER	SOPORTE FARO TRAS
14	0288	0288	BAVETTE DE FILTRE	FILTER GUARD	BAVETTE FILTRO
15	0576	0576	VIS AUTO FIL 4.9 X 13 LONG	SCREW AUTO THREADING 4.9 X 13 L	TORNILLO AUTORROSCANTE 4.9 X 13 L
16	0547	0547	VIS 6X30	SCREW 6X30	TORNILLO 6X30
17	0546	0546	VIS 6X20	SCREW 6X20	TORNILLO 6X20
18	M321	M321	RONDELLE	WASHER	ARANDELA
19	0656	0656	VIS 6X30	SCREW	TORNILLO
20	0565	0565	ENTRETOISE INOX CARROSSERIE	SPACER INOX BOODY	CASQUILLO INOX CARROCERIA
21	0495	0495	BOUCHON CORP INJECTION	CAP INJECTION BOODY	TAPÓN CUERPO INYECCIÓN
22	0530	0530	DZUS DE SELLE	DZUS DE SELLE	DZUS DE SELLE
23	0532	0532	RONDELLE PLASTIQUE DZUS	WASHER PLASTIQUE DZUS	ARANDELA PLAST. DZUS
24	0533	0533	RONDELLE VEROUILLAGE DZUS	WASHER VEROUILLAGE DZUS	ARANDELA VEROUILLAGE DZUS
25	0575	0575	VIS AUTO FIL 4.8 X 9.5	SCREW AUTO TREADING 4.8 X 9.5	TORNILLO AUTO ROSCANTE 4.8 X 9.5
26	0238	0238	BUTEE PLASTIQUE	ROBBER TANK	TOPE GOMA

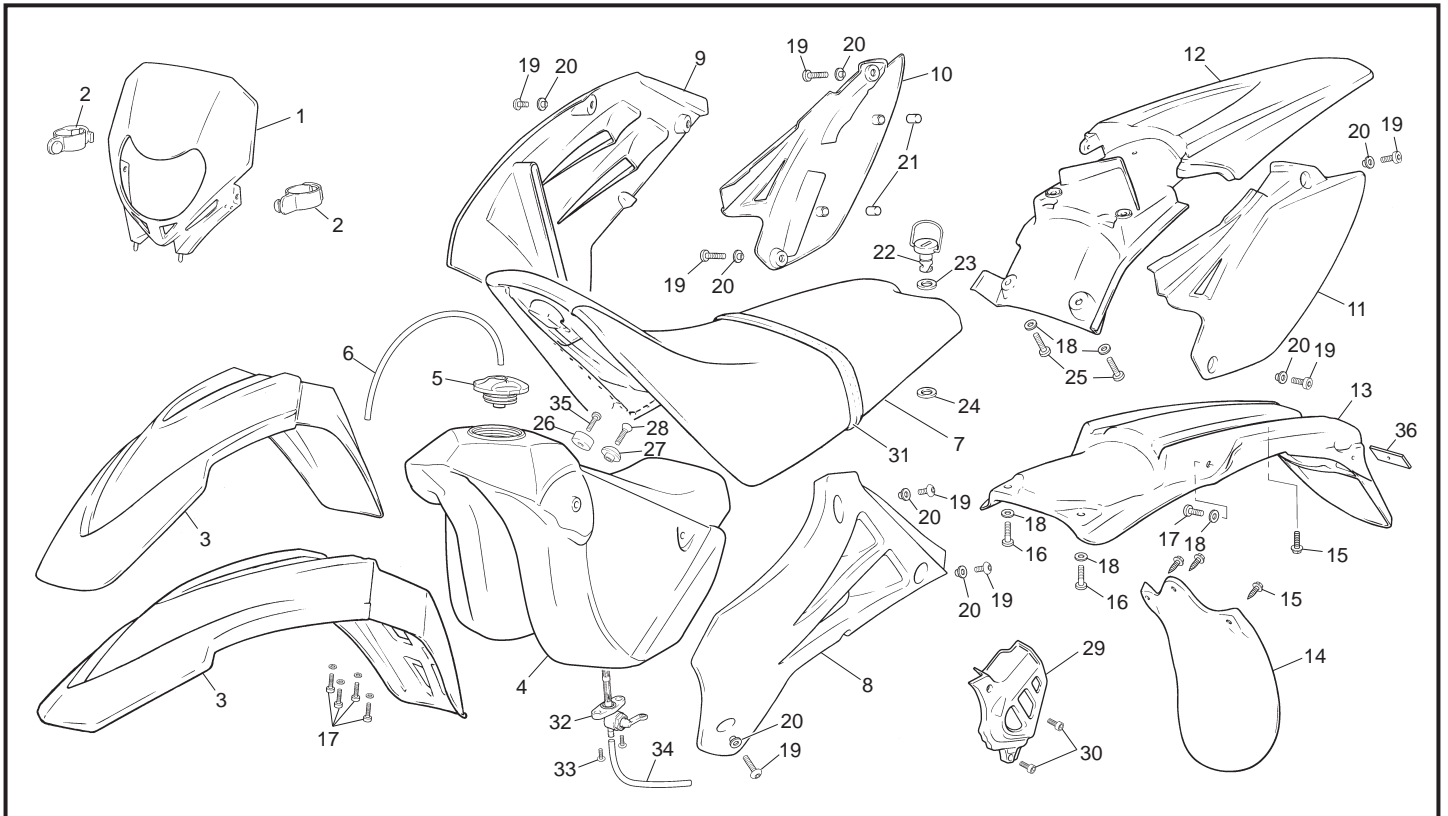

POS.	125 SM	125 END	FRANÇAIS	ENGLISH	ESPAÑOL
27	0497	0497	FIXATION SELLE RESERVOIR	SPACER SEAT /TANK	CASQUILLO SILING DEPÓSITO
28	0652	0652	VIS M6X25	SCREW M6X25	TORNILLO M6X25
29	Y646	Y646	CACHE PIGNON PLASTIQUE 125	FRONT SPROCKET PROTECTOR 125	PROTECTOR PIÑÓN SALIDA 125
30	Y647	Y647	VIS	SCREW	TORNILLO
31	0793	0793	SANGLE HOM.	HANDLE	ASA
32	C023	C023	ROBINET D'ESSENCE	PETROL TAP	GRIFO GASOLINA
33	M282	M282	VIS BHC 6X10	SCREW BHC 6X10	TORNILLO 6X10 ULS
34	H046	H046	DURITE	PETROL HOSE	TUBO GASOLINA
35	C410	C410	VIS 6X25 CHC	SCREW 6X25	TORNILLO 6X25
36	1256	1256	CATADIOPTRE AR/SPORT	REAR REFLECTOR	CATADIÓPTICO AR/SPORT

Adhesif / Sticker / Adhesivo

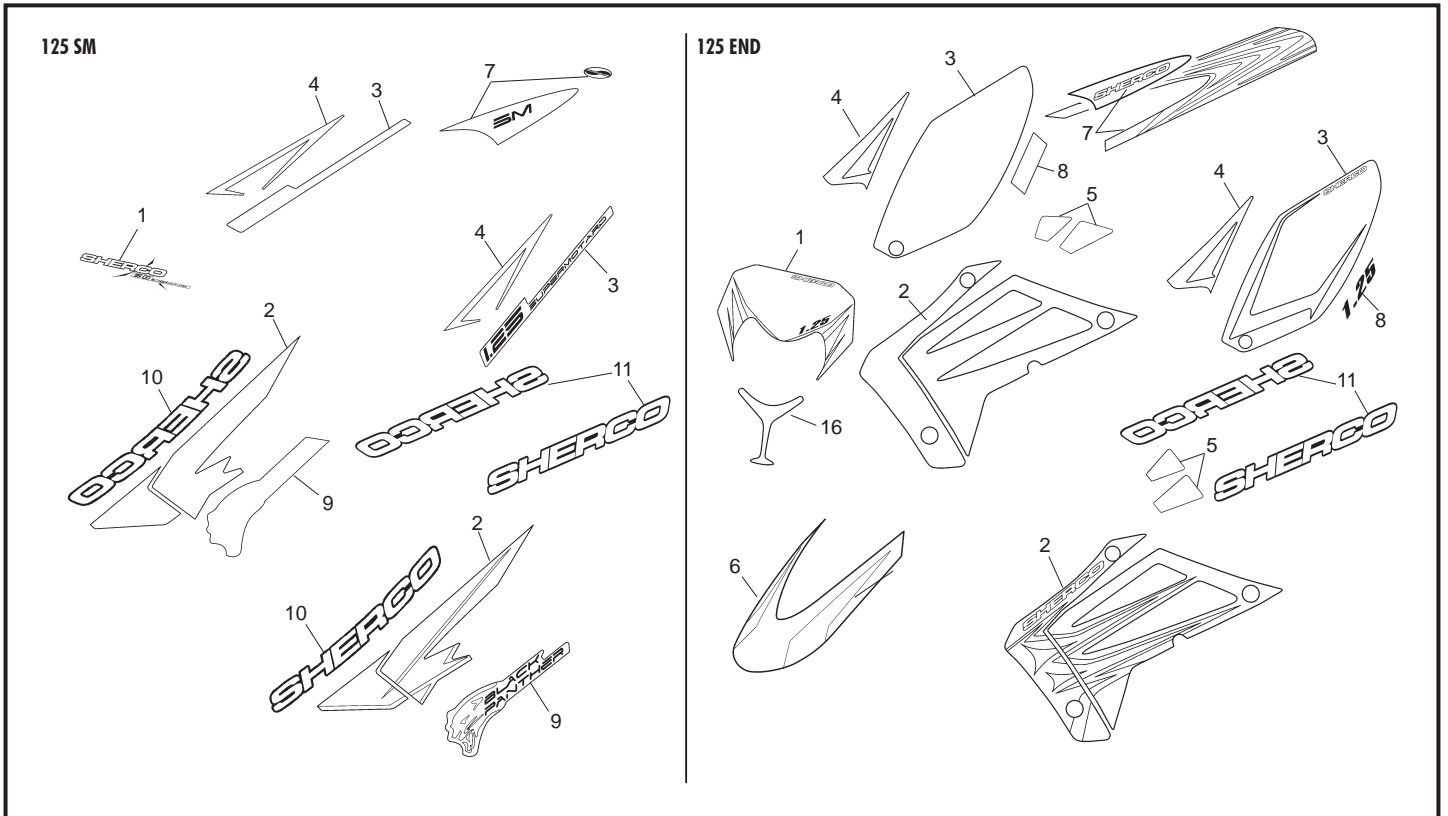

POS.	125 SM	125 END	FRANÇAIS	ENGLISH	ESPAÑOL
1	1586	2291	ADH.ADH. PLAQUE PHARE	HEADLIGHT STICKER	ADH. PLACA FARO
2	1587	1930	ADH. OUIE JEU	RADIATOR GUARD STICKERS (PAIR)	ADH. TAPA RADIADOR JUEGO
3	-----	2290	ADH. PLAQUE NUM. JEU	SIDE NUMBER STICKERS (PAIR)	ADH. PLACA NÚMERO JUEGO
4	0790	0825	ADH. PLAQUE LAT DECO PAIRE	SIDE COVER STICKERS (PAIR)	ADH. TAPA LAT DECO JUEGO
5	-----	0588	ADH. OMBRE JEU COMP	BLACK STICKERS	ADH. SOMBRAS JUEGO COMP
6	-----	1877	ADH. PARE BOUE AVANT	STICKER FRONT MUDGARD	ADH. GUARDABARRO DELANTERO
7	0792	2295	ADH. PARE BUOE ARRIERE	STICKER PEAR MUDGARD	ADH. GUARDABARRO TRASERO
8	-----	2935	ADH. JEU 125 08	STICKER PAIR 125 08	ADHESIVO JUEGO 125 08
9	0809	-----	ADH. BLACK PANTHER	STICKER BLACK PANTHER	ADH. BLACK PANTHER
10	0810	-----	ADH. SHERCO CURVE CROME	STICKER SHERCO CURVE CHROME	ADH. SHERCO CURVA CROMA
11	H307	H307	ADHESIF BRAS	STICKER	ADHESIVO BASCULANTE
16	2296	2296	ADHESIF PHARE	STICKER FRONT LIGHT	ADHESIVO FARO

Cylindre / Cylinder / Cilindro

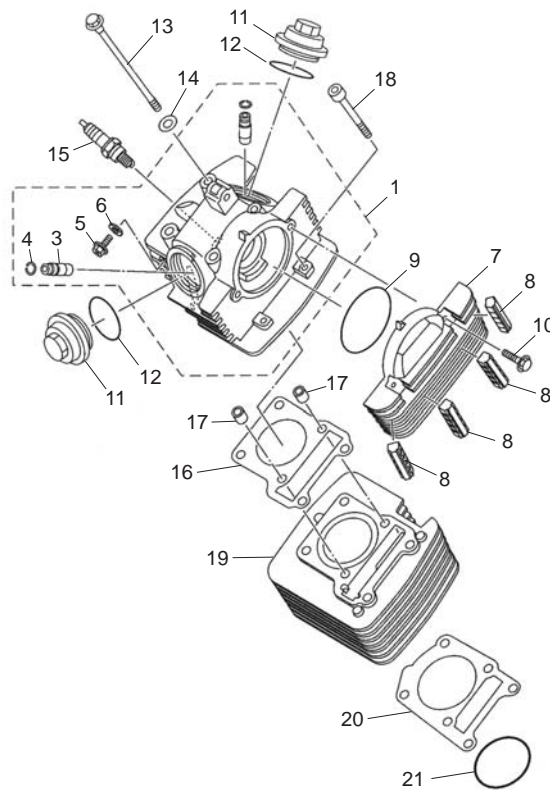

POS.	125	FRANÇAIS	ENGLISH	ESPAÑOL
1	Y778	CULASSE	HEAD CYLINDER	CONJUNTO CULATA
2	Y501	GUIDE VALVE ADMISSION	GUIDE INTAKE VALVE	GUÍA VÁLVULA ADMISIÓN
3	Y502	GUIDE VALVE ECHAPPEMENT	GUIDE EXHAUST VALVE	GUÍA VÁLVULA ESCAPE
4	Y781	CIRCLIP	CIRCLIP	CIRCLIP
5	Y782	VIS TH	SCREW HEXAGON	TORNILLO CONTROL FLUJO DE ACEITE
6	Y783	JOINT	GASKET	ARANDELA
7	Y784	CACHE CULASSE CYLINDRE	COVER CYLINDER HEAD SIDE	TAPA LATERAL CULATA
8	Y785	CAOUTCHOUC ANTIVIBRATION	SOUND ABSORBER	GOMA ANTIVIBRACION
9	Y786	JOINT TORIQUE	O-RING	TÓRICA CIERRE TAPA DE VÁLVULA
10	Y787	VIS AVEC RONDELLE	BOLT FLANGE	TORNILLO M6 TAPA LATERAL
11	Y788	BOUCHON REGLAGE BASCULEUR	COVER CYLINDER HEAD SIDE	TAPA DE VÁLVULA
12	Y789	JOINT TORIQUE	O-RING	TÓRICA CIERRE TAPA DE VÁLVULA
13	Y512	VIS AVEC RONDELLE	BOLT FLANGE	TORNILLO M6 TAPA LATERAL
14	Y791	RONDELLE PLATE	WASHER PLATE	ARANDELA TORNILLO CULATA
15	Y514	BOUGIE NGK CR6HSA	PLUG SPARK NGK CR6HSA	BUJÍA NGK CR6HSA
16	Y792	JOINT DE CULASSE	GASKET CYLINDER HEAD	JUNTA DE CULATA
17	Y516	PION CENTREUR	PIN DOWEL	ESPIGA CENTRADORA
18	Y794	VIS	BOLT	TORNILLO
19	Y795	CYLINDRE	CYLINDER	CILINDRO
20	Y796	JOINT D'EMBASE	GASKET CYLINDER	JUNTA CILINDRO
21	Y797	JOINT TORIQUE	O-RING	TÓRICA CIERRE CILINDRO

Villebrequin assemble / Crankshaft assembly / Cigüeñal biela

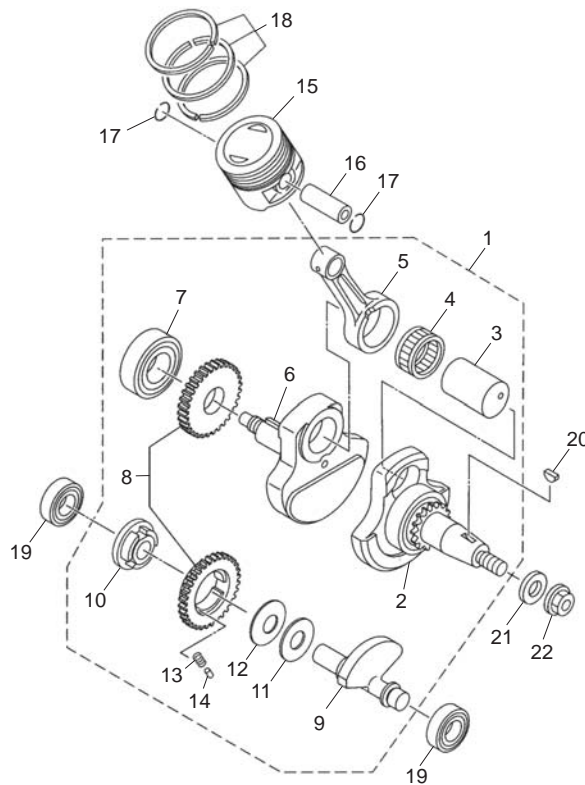

POS.	125	FRANÇAIS	ENGLISH	ESPAÑOL
1	Y798	VILLEBREQUIN ASSEMBLE	CRANKSHAFT ASS	CIGÜEÑAL BIELA
2	Y799	MASSE COTE ALLUMAGE	CRANK IGNITION SIDE	MANIVELA CIGÜEÑAL LADO IZQ.
3	Y800	MANETTON BIELLE	PIN CRANK	CODO DE CIGÜEÑAL
4	Y524	ROULEMENT	BEARING	RODAMIENTO
5	Y801	BIELLE	ROD CONNECTING	BIELA
6	Y802	MASSE VILO COTE DROIT	CRANK RIGHT SIDE	MANIVELA CIGÜEÑAL LADO DERECHO
7	Y803	ROULEMENT	BEARING	RODAMIENTO
8	Y804	BALANCIER D'ÉQUILIBRAGE ASS	GEAR BALANCE WELGHT ASSY	EJE BALANCE ASSY
9	Y805	BALANCIER D'ÉQUILIBRAGE	WEIGHT	EJE BALANCE
10	Y806	AMORTISSEUR DE CHOC	BUFFER	AMORTIGUADOR
11	Y807	PLAT D'AMORTISSEUR	PLATE ABSORBER	TORNILLO
12	Y808	RONDELLE CONIQUE	WASHER CONICAL SPRING	ARANDELA CONICO
13	Y809	RESSORT DE COMPRESSION	SPRING COMPRESSION	RESORTE
14	Y810	AXE	PIN DOWEL	BULON
15	Y811	PISTON	PISTON	PISTON
16	Y812	AXE DE PISTON	PIN PISTON	BULON PISTÓN
17	Y813	CIRCLIP	CIRCLIP	CIRCLIP
18	Y814	SEGMENT STD	PISTON RING SET STD	CONJUNTO AROS PISTÓN
19	Y815	ROULEMENT	BEARING	RODAMIENTO
20	Y539	CLAVETTE DEMI LUNE	KEY WOODRUFF	CHAVETA MEDIALUNA
21	Y540	RONDELLE PLATE	WHASHER PLATE	ARANDELA PLANA
22	Y818	ECROU	NUT FLANGE	TUERCA

Soupape / Valve / Válvula

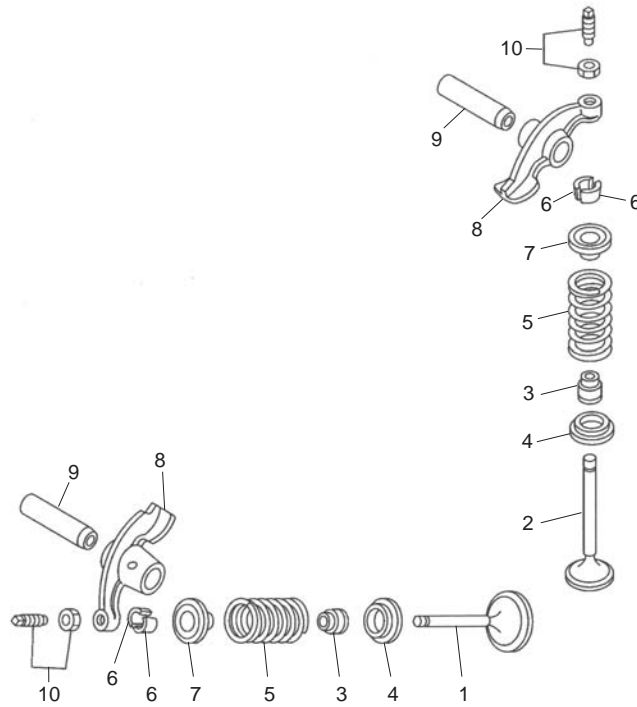

POS.	125	FRANÇAIS	ENGLISH	ESPAÑOL
1	Y819	SOUPAPE D'ADMISSION	CVALVE INTAKE	VÁLVULA ADMISIÓN
2	Y820	SOUPAPE D'ÉCHAPPEMENT	VALVE EXHAUST	VÁLVULA DE ESCAPE
3	Y821	LARMIER SOUPAPE	SEAL VALVE STEM	ANILLO DE RETENCIÓN
4	Y822	RONDELLE APPUI RESSORT	SEAL VALVE SPRING	ASIENTO RESORTE VÁLVULA
5	Y823	RESSORT SOUPAPE	SPRING VALVE	RESORTE VÁLVULA
6	Y824	DEMI CLAVETTE SOUPAPE	COTTER VALVE	BICONO DE VÁLVULAS
7	Y825	RONDELLE RETENUE SOUPAPE	RETAINER VALVE SPRING	ASIENTO DE BICONO DE VÁLVULA
8	Y826	BASCULEUR	ARM VALVE ROCKER	BALANCÍN
9	Y827	AXE BASCULEUR	SHAFT ROCKER	EJE DE BALANCÍN
10	Y828	VIS REGLAGE VALVE+ECROU	SCREW VALVE ADJSUTING	TORNILLO DE AJUSTE DE VÁLVULA

Systeme distribution / Distribution system / Sistema distribución

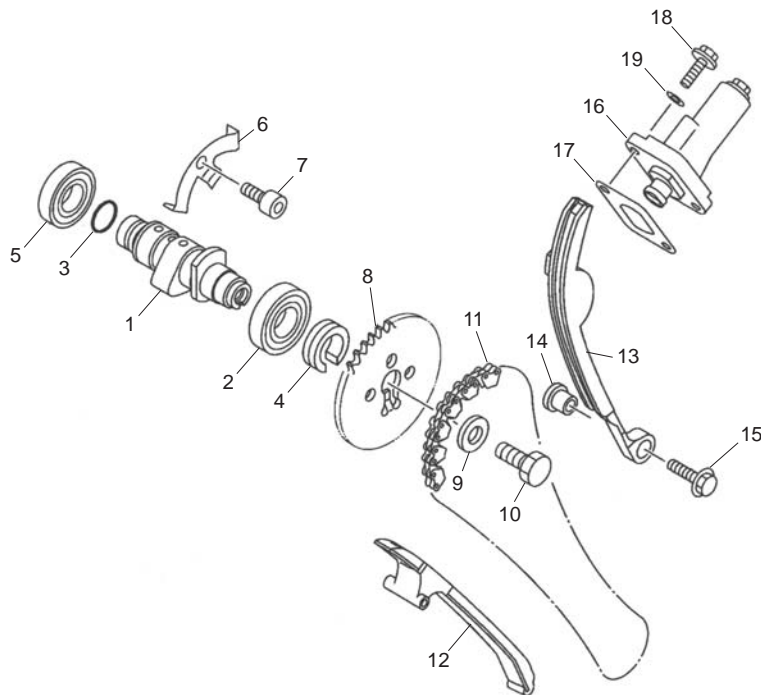

POS.	125	FRANÇAIS	ENGLISH	ESPAÑOL
1	Y829	ARBRE À CAM	CAMSHAFT	ÁRBOL DE LEVAS
2	Y830	ROULEMENT	BEARING	RODAMIENTO
3	Y831	JOINT TORIQUE	O-RING	ANILLO
4	Y832	PION DE CENTRAGE	COLLAR	CASQUILLO GUÍA
5	Y833	ROULEMENT	BEARING	RODAMIENTO
6	Y834	PLAQUE DE RETENUE	PLATE	RETENCIÓN
7	Y835	VIS	BOLT	TORNILLO
8	Y836	PIGNON ENTRAINEMENT CHAINE	SPROCKET CAM CHAIN	PIÑÓN CADENA
9	Y559	RONDELLE PLATE	WHASHER PLATE	ARANDELA PLANA
10	Y838	VIS	BOLT	TORNILLO
11	Y839	CHAÎNE	CHAIN	CADENA DE DISTRIBUCIÓN
12	Y840	PATIN DE CHAINE	GUIDE STOPPER	TOPE DE GUÍA CADENA
13	Y841	PATIN DE CHAINE TENDEUR	GUIDE STOPPER	TOPE DE GUÍA CADENA
14	Y842	PION DE CENTRAGE	COLLAR	CASQUILLO GUÍA
15	Y843	VIS	BOLT FLANCHE	TORNILLO
16	Y844	TENDEUR DE CHAINE	TENSIONER ASSY	TENSOR CADENA DE DISTRIBUCIÓN
17	Y845	JOINT TENDEUR DE CHAINE	GASKET TENSIONER CASE	JUNTA TENSOR
18	Y846	VIS AVEC RONDELLE	BOLT FLANGE	TORNILLO CON ARANDELA
19	Y569	RONDELLE	GASKET	JUNTA TORNILLO

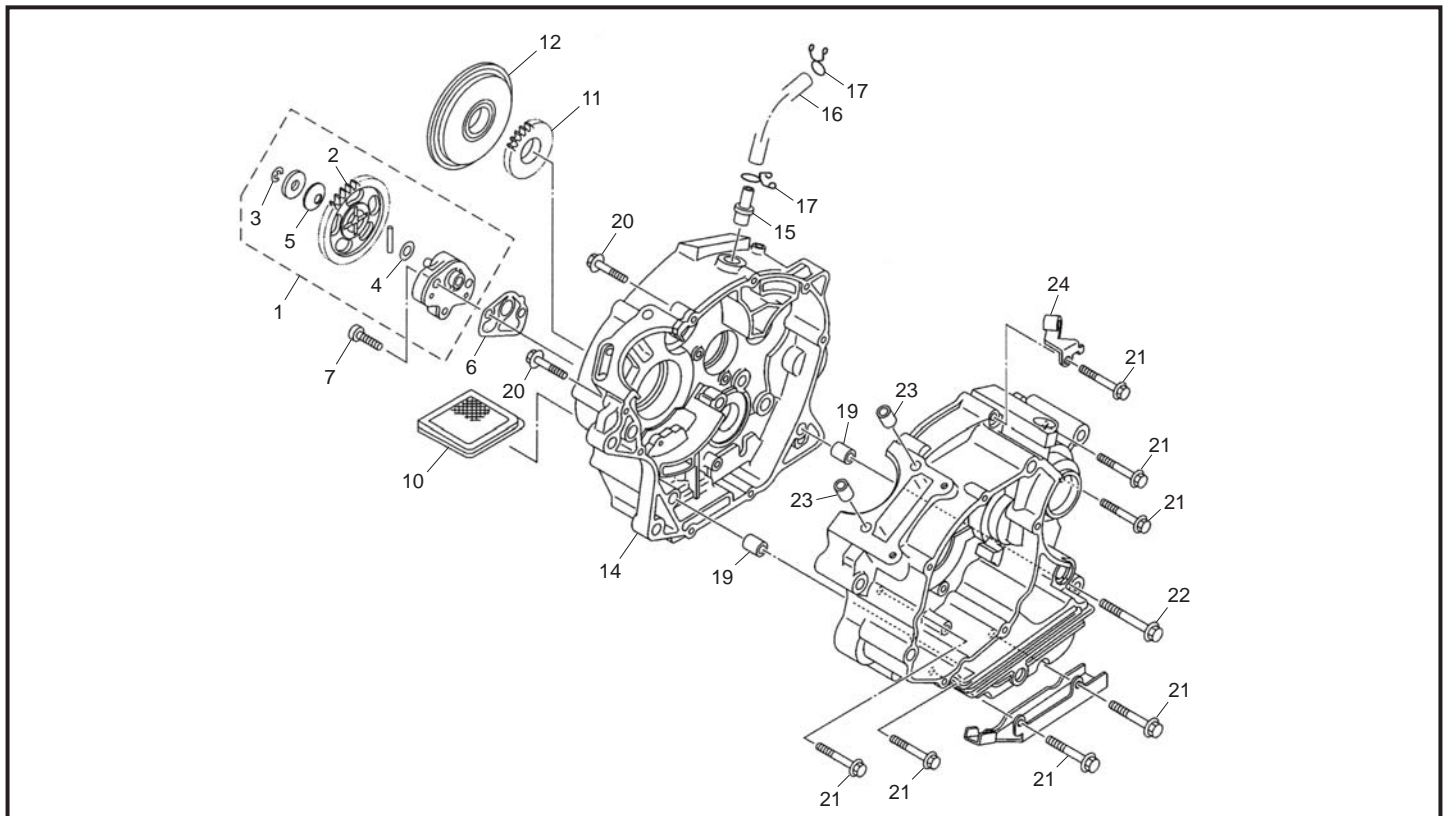
Carter centraux / Central crankcase / Carter central

POS.	125	FRANÇAIS	ENGLISH	ESPAÑOL
1	Y848	POMPE A HUILE ASS	OIL PUMP ASSY	BOMBA DE ACEITE COMPLETA
2	Y849	PIGNON ENTRAINEMENT POMPE	GEAR PUMP DRIVEN	ENGRANAJE TRACCIÓN BOMBA
3	Y572	CIRCLIP	CIRCLIP	CIRCLIP
4	Y574	RONDELLE PLATE	WHASER PLATE	ARANDELA PLANO
5	Y573	RONDELLE CONIQUE	WHASHER CONICAL SPRING	ARANDELA CÓNICO
6	Y853	JOINT DE COUVERCLE DE POMPE	GASKET PUMP COVER	JUNTA TAPA DE BOMBA
7	Y854	VIS DE POMPE	SCREW FLAT FILLISTER	TAPA BOMBA
8	Y576	VIS DE VIDANGE	PLUG STRAIGHT SCREW	TAPÓN DE VACIADO
9	Y577	JOINT	GASKET	JUNTA
10	Y578	CREPINE	STRAINER OIL	FILTRO DE ACEITE
11	Y858	PIGNON ENTRAINEMENT POMPE	GEAR PUMP DRIVE	ENGRANAJE TRACCIÓN BOMBA
12	Y859	FILTRE ROTATIF	FILTER ROTARY	FILTRO ROTATIVO
13	Y864	CARTER GAUCHE	CRANKCASE LEFT	CARTER IZQUIERDA
14	Y865	CARTER DROIT	CRANKCASE RIGHT	CARTER DERECHA
15	Y866	TUBE RENIFLARD	PIPE BREATHER	ESPIGA RESPIRADERO
16	Y867	TUBE RENIFLARD	PIPE BREATHER	ESPIGA RESPIRADERO
17	Y868	COLLIER CLIP	CLIP	PRESILLA
18	Y869	BRIDE	CLAMP	BRIDA
19	Y870	PION DE CENTRAGE	PIN DOWEL	PASADOR DE ESPIGA
20	Y871	VIS M6	BOLT FLANGE M6	TORNILLO M6
21	Y872	VIS M6	BOLT FLANGE M6	TORNILLO M6
22	Y873	VIS M6	BOLT FLANGE M6	TORNILLO M6
23	Y870	PION DE CENTRAGE	PIN DOWEL	PASADOR DE ESPIGA
24	Y874	SUPPORT CABLE EMBRAYAGE	HOLDER CLUTCH CABLE	SOSTÉN CABLE DE EMBRAGUE

Carter latreaux / Lateral crankcase / Carter lateral

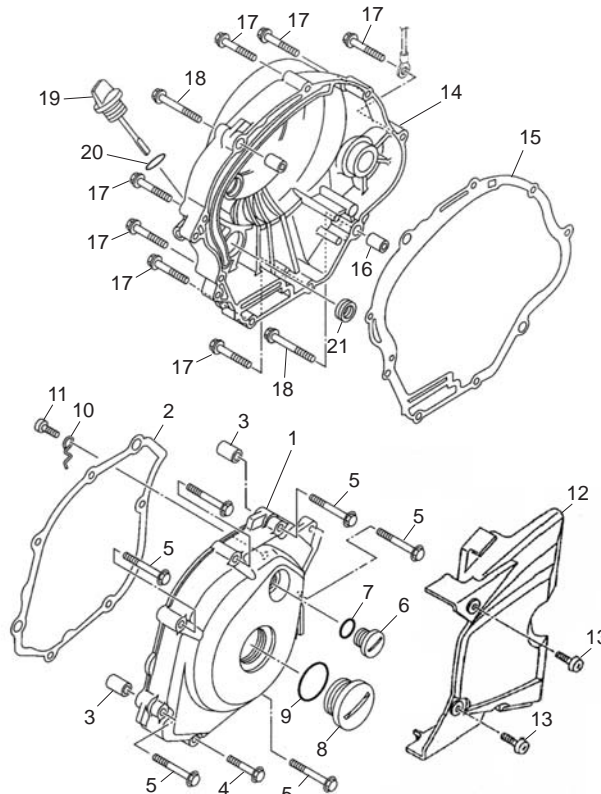

POS.	125	FRANÇAIS	ENGLISH	ESPAÑOL
1	Y875	CACHE LATERAL GAUCHE	COVER CRANKCASE LEFT	TAPA CARTER IZQUIERDA
2	Y876	JOINT DE CARTER GAUCHE	GASKET CRANKCASE LEFT	JUNTA TAPA CARTER IZQUIERDA
3	Y870	PION DE CENTRAGE	PIN DOWEL	CASQUILLO CENTRADOR
4	Y878	VIS M6	BOLT FLANGE M6	TORNILLO M6
5	Y878	VIS M6	BOLT FLANGE M6	TORNILLO M6
6	Y880	VIS REGARD	PLUG STRAIGHT SCREW	TAPÓN DE CONTROL
7	Y881	JOINT TORIQUE	O-RING	TÓRICA TAPÓN DE CONTROL
8	Y882	VIS REGARD	PLUG STRAIGHT SCREW	TAPÓN CENTRAL
9	Y883	JOINT TORIQUE	O-RING	TÓRICA TAPÓN DE CONTROL
10	Y884	FIX CABLE	PLATE	FIJADOR
11	Y885	VIS CRICIFORME	SCREW PAN HEAD	TORNILLO FIJADOR
12	Y886	CACHE PIGNON	COVER CHAIN CASE	CUBRE CADENA
13	Y887	VIS	SCREW BIND	TORNILLO
14	Y888	CACHE LATERAL DROIT	COVER CRANKCASE RIGHT	TAPA CARTER DERECHA
15	Y889	JOINT DE CARTER DROIT	GASKET CRANKCASE RIGHT	JUNTA TAPA CARTER DERECHA
16	Y870	PION DE CENTRAGE	PIN DOWEL	CASQUILLO CENTRADOR
17	Y878	VIS M6	BOLT FLANGE M6	TORNILLO M6
18	Y872	VIS M6	BOLT FLANGE M6	TORNILLO M6
19	Y893	BOUCHON NIVEAU D'HUILE	PLUG OIL LEVEL	TAPÓN DE NIVEL ACEITE
20	Y877	JOINT TORIQUE	O-RING	TÓRICA NIVEL DE ACEITE
21	Y890	JOINT SPI	OIL SEAL	RETEN

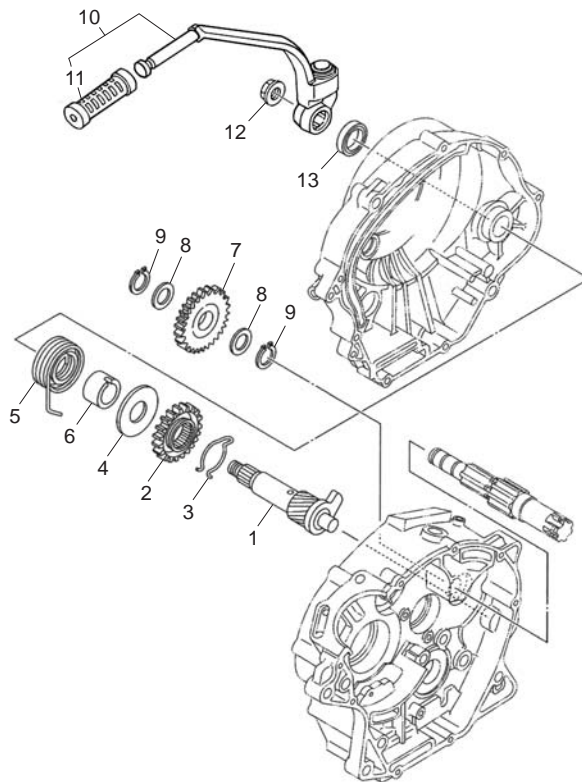
Systeme demarreur / Start system / Sistema arranque

POS.	125	FRANÇAIS	ENGLISH	ESPAÑOL
1	Y891	ARBRE DE KICK	KICK AXLE ASSY	EJE PEDAL ARRANQUE
2	Y892	PIGNON	GEAR KICK	ENGRANAJE PEDAL ARRANQUE
3	Y894	CLIP	CLIP	CLIP
4	Y895	RONDELLE PLATE	WASHER PLATE	ARANDELA PLANA
5	Y896	RESSORT DE TORSION	SPRING TORSION	MUELLE DE TORSIÓN
6	Y897	ENTRETOISE	SPACER	CASQUILLO
7	Y898	PIGNON FOU	GEAR KICK IDLE	PINÓN LIBRE PEAL ARRANQUE
8	Y899	RONDELLE PLATE	WASHER PLATE	ARANDELA PLANA
9	Y664	CIRCLIP	CIRCLIP	CIRCLIP
10	Y901	KICK COMPLET	KICK CRANK ASSY	PEDAL ARRANQUE
11	Y902	PROTECTION PLASTIQUE	COVER KICK LEVER	GOMA PEDAL
12	Y667	ECROU M12	NUT M12	TUERCA M12
13	Y904	JOINT SPY	OIL SEAL	RETENEDOR

Ensemble allumage / Ignition system / Sistema de encendido

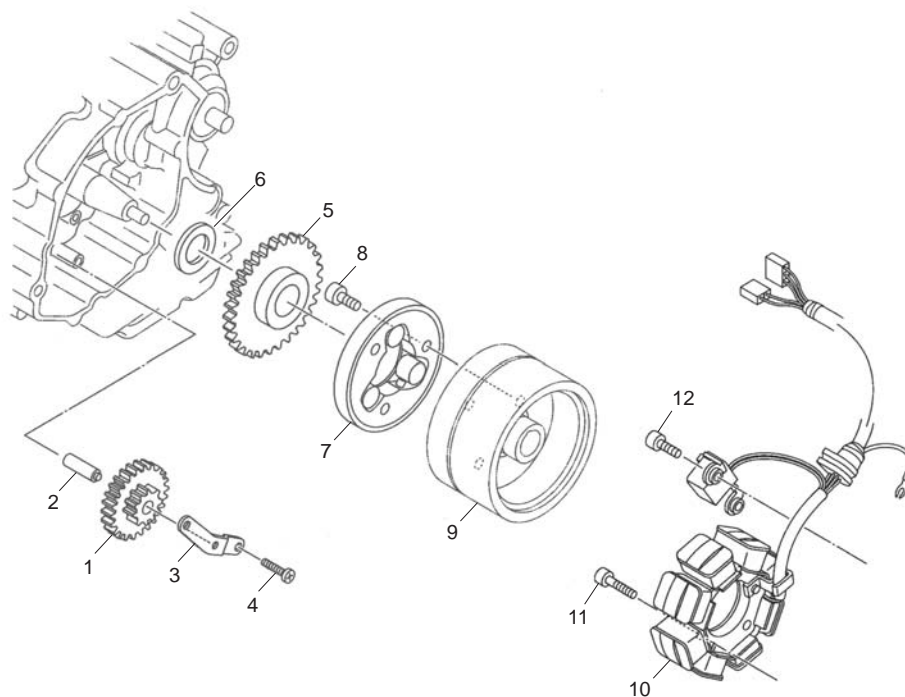

POS.	125	FRANÇAIS	ENGLISH	ESPAÑOL
1	Y905	PIGNON NEUTRE	GEAR IDLER	PIÑÓN ARRANQUE
2	Y906	ARBRE	SHAFT	EJE
3	Y907	PLAQUE DE VERROUILLAGE	PLATE IDLE GEAR	PLATINA PIÑÓN DE ARRANQUE
4	Y908	VIS	SCREW PAN HEAD	TORNILLO
5	Y909	PIGNON	GEAR IDLER	PIÑÓN
6	Y910	RONDELLE PLATE	WASHER PLATE	ARANDELA PLANA
7	Y911	ROUE LIBRE	STARTER CLUTCH OUTER ASSY	RUEDA LIBRE
8	Y676	VIS	BOLT	TORNILLO
9	Y766	ROTOR COMPLET	ROTOR ASSY	ROTOR COMPLETO
10	Y765	STATOR COMPLET	STATOR ASSY	ESTATOR COMPLETO
11	Y982	VIS	SCREW	TORNILLO
12	Y983	VIS	SCREW	TORNILLO

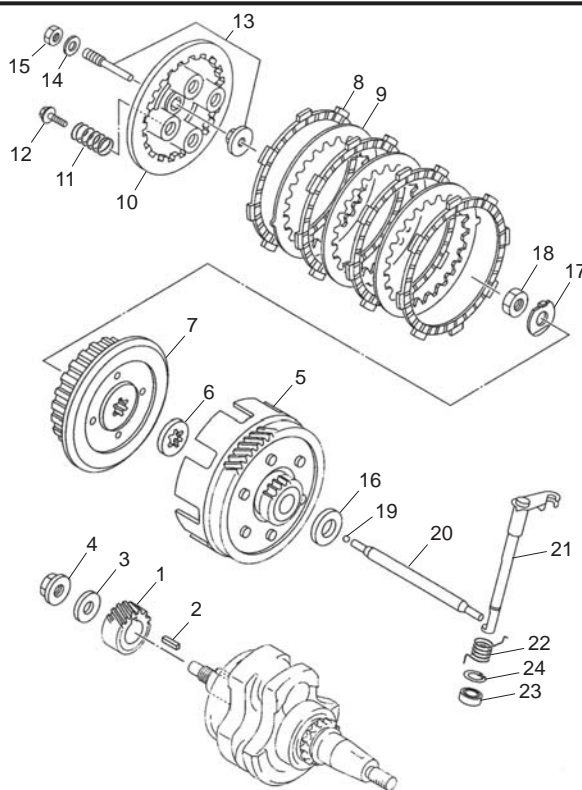

POS.	I25	FRANÇAIS	ENGLISH	ESPAÑOL
1	Y912	PIGNON	GEAR PRIMARY DRIVE	CORONA TRANS PRIMARIA
2	Y678	CLAVETTE	KEY STAIGHT	CHAVETA RECTA
3	Y914	RONDELLE PLATE	WASHER PLATE	ARANDELA PLATA
4	Y667	ECROU M12	NUT M12	TUERCA M12
5	Y916	CLOCHE EMBRAYAGE	CLUTCH BASKET ASS	CAMPANA DE EMBRAGUE
6	Y917	RONDELLE	PLATE THRUST	ARANDELA
7	Y918	NOIX D'EMBAYAGE	CLUTCH HUB	CUBO DE EMBRAGUE
8	Y919	DISQUE DE FRICTION	PLATE FRICTION	DISCO DE EMBRAGUE
9	Y920	DISQUE LISSE	PLATE CLUTCH	PLATO DE FRICCIÓN
10	Y921	PLATEAU DE PRESSION	PLATE PRESSURE	PLATO DE PRESIÓN
11	Y922	RESSORT D'EMBAYAGE	SPRING CLUTCH	MUELLE DE COMPRESIÓN
12	Y923	VIS EPAULE	SCREW SPRING	TORNILLO CON ARANDELA
13	Y924	MÉCANISME DE POUSSÉ COMPLET	PUSH LEVER ASS	EMPUJE CPL
14	Y925	RONDELLE	WASHER	ARANDELA
15	Y926	ECROU	NUT	TUERCA
16	Y927	RONDELLE FRICTION	PLATE THRUST	ARANDELA
17	Y696	RONDELLE DE BLOCAGE	WASHER LOCK	ARANDELA DE CIERRA
18	Y697	ECROU	NUT	TUERCA
19	Y930	BILLE	BALL	BOLA
20	Y931	AXE DE POUSSÉ	ROD PUSH	VARILLA DE EMPUJE
21	Y932	LEVIER D'EMBAYAGE	PUSH LEVER	PALANCA DE EMPUJE
22	Y933	RESSORT DE TORSION	SPRING TORSION	MUELLE DE TORSIÓN
23	Y934	JOINT SPI	OIL SEAL	RETEN
24	Y703	CIRCLIP	CIRCLIP	PRESILLA RONDADA

Transmission / Transmission / Transmisión

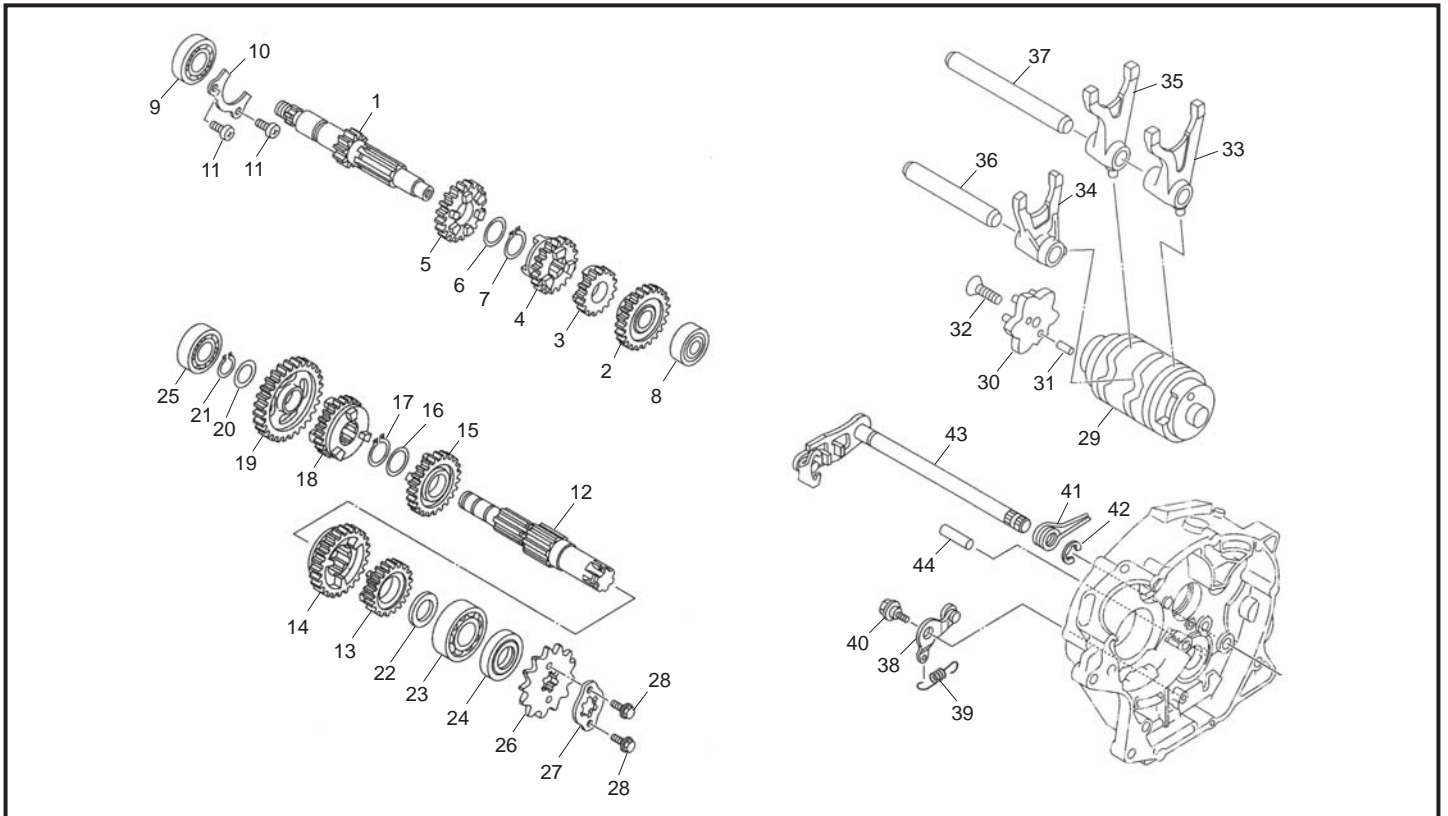

POS.	125	FRANÇAIS	ENGLISH	ESPAÑOL
1	Y915	AXE PRIMAIRE	AXLE MAIN	TEJE PRIMARIO
2	Y936	PIGNON 5TH Z=24	GEAR 5TH PINION	PIÑÓN DE 5
3	Y937	PIGNON 2ND Z=19	GEAR 2ND PINION	PIÑÓN DE 2
4	Y938	PIGNON 3RD Z=19	GEAR 3RD PINION	PIÑÓN DE 3
5	Y939	PIGNON 4TH Z=22	GEAR 4TH PINION	PIÑÓN DE 4
6	Y709	RONDELLE PLATE	WHASHER PLATE	ARANDELA
7	Y710	CIRCLIP	CIRCLIP	CIRCLIP
8	Y942	ROULEMENT	BEARING	RODAMIENTO
9	Y943	ROULEMENT	BEARING	RODAMIENTO
10	Y944	PLAQUE BUTÉE	PLATE COVER	PLACA FIJACIÓN RODAMIENTO
11	Y945	VIS	SCREW PAN HEAD	TORNILLO
12	Y946	ARBRE SECONDAIRE ASSY	DRIVE AXLE ASSY	EJE SECUNDARIO
13	Y947	PIGNON 5TH Z=21	GEAR 5TH WHEEL	RUEDA DE 5
14	Y948	PIGNON 2ND Z=32	GEAR 2ND WHEEL	RUEDA DE 2
15	Y949	PIGNON 3RD Z=25	GEAR 3RD WHEEL	RUEDA DE 3
16	Y709	RONDELLE PLATE	WHASHER PLATE	ARANDELA
17	Y710	CIRCLIP	CIRCLIP	CIRCLIP
18	Y952	PIGNON 4TH Z=23	GEAR 4TH WHEEL	RUEDA DE 4
19	Y953	PIGNON 1ST Z=37	GEAR 1ST WHEEL	RUEDA DE 1
20	Y954	RONDELLE PLATE	WHASHER PLATE	ARANDELA PLANA
21	Y955	CIRCLIP	CIRCLIP	CIRCLIP
22	Y725	RONDELLE PLATE	WHASHER PLATE	ARANDELA PLANA
23	Y957	ROULEMENT	BEARING	RODAMIENTO
24	Y958	JOINT SPI	OIL SEAL	JUNTA SPI
25	Y728	ROULEMENT	BEARING	RODAMIENTO
26	Y729	PIGNON SORTIE DE BOITE 14	SPROCKET DRIVE 14	PIÑÓN SALIDA DENRADO 14
27	Y960	CLIP DE VERROUILLAGE	HOLDER SPROCKET	SOPORTE PIÑÓN
28	Y950	VIS	BOLT FLANGE	TORNILLO
29	Y951	BARRILLET DE SELECTION	SHIFT CAM ASSY	TAMBOR SELECTOR
30	Y733	ETOILE DE SELECTION	SEGMENT	ESTRELLA
31	Y962	PION	PIN DOWEL	PASADOR DE CLAVIJA
32	Y963	VIS	SCREW	TORNILLO
33	Y964	FOURCHETTE DE SELECTION 1	FORK SHIFT 1	HORQUILLA DEL CAMBIO 1
34	Y965	FOURCHETTE DE SELECTION 2	FORK SHIFT 2	HORQUILLA DEL CAMBIO 2

Transmission / Transmission / Transmisión

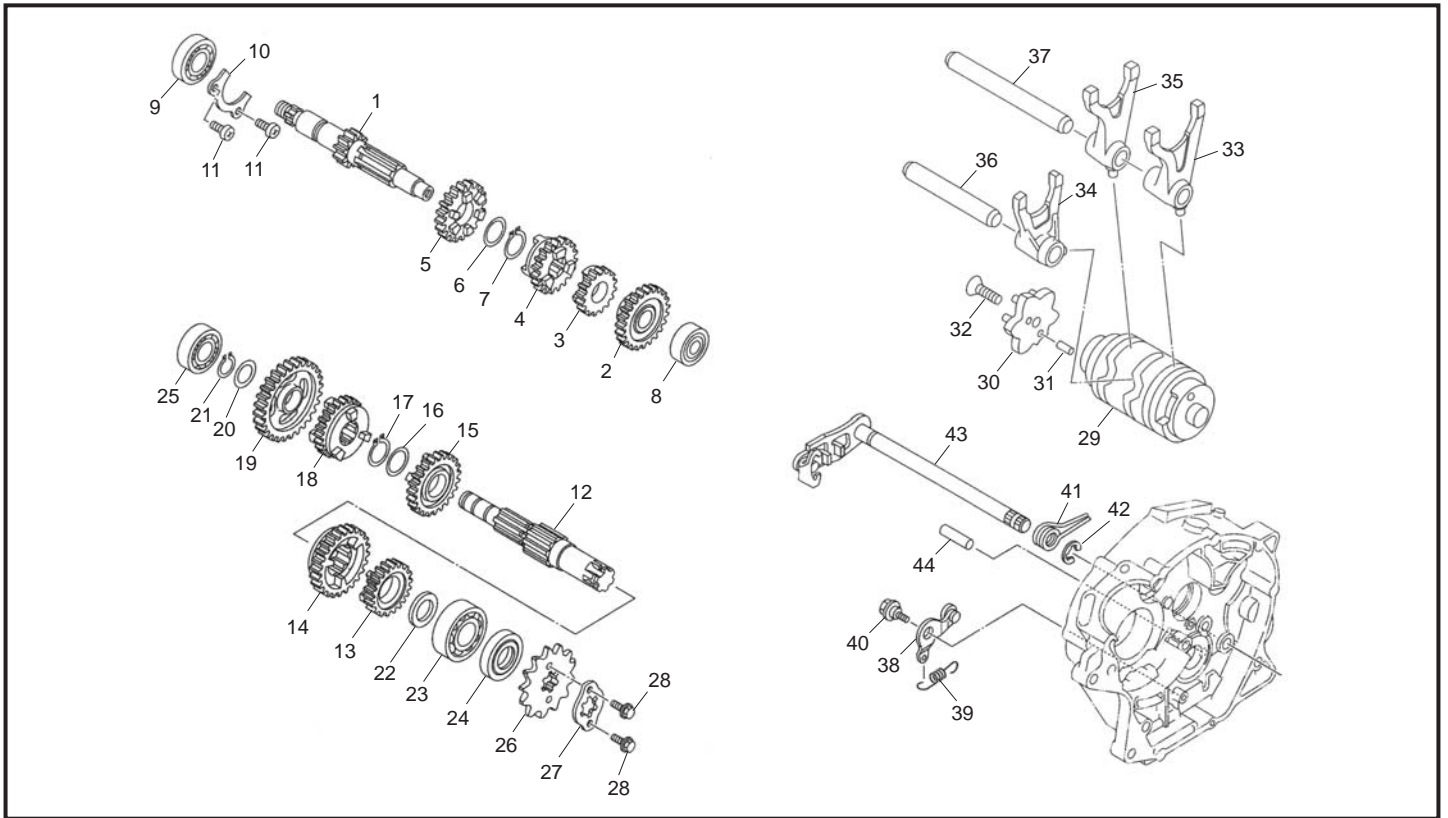

POS.	125	FRANÇAIS	ENGLISH	ESPAÑOL
35	Y966	FOURCHETTE DE SELECTION 3	FORK SHIFT 3	HORQUILLA DEL CAMBIO 3
36	Y967	AXE DE FOURCHETTE	BAR SHIFT FORK GUIDE 1	EJE HORQ. CAMBIO 1
37	Y968	AXE DE FOURCHETTE	BAR SHIFT FORK GUIDE 2	EJE HORQ. CAMBIO 2
38	Y969	LEVIER DE BUTÉE	STOPPER LEVER ASSY	PALANCA DE TOPE
39	Y970	RESSORT	SPRING	MUELLE
40	Y971	VIS DE BLOCAGE	BOLT STOPPER	TORNILLO
41	Y744	RESSORT DE TORSION	SPRING TORSION	MUELLE DE TORSIÓN
42	Y745	CIRCLIP	CIRCLIP	CIRCLIP
43	Y746	ARBRE DE SELECTION	SHIFT SHAFT ASSY	EJE SELECTOR

Demarreur électrique / Electrical starter / Arranque eléctrico

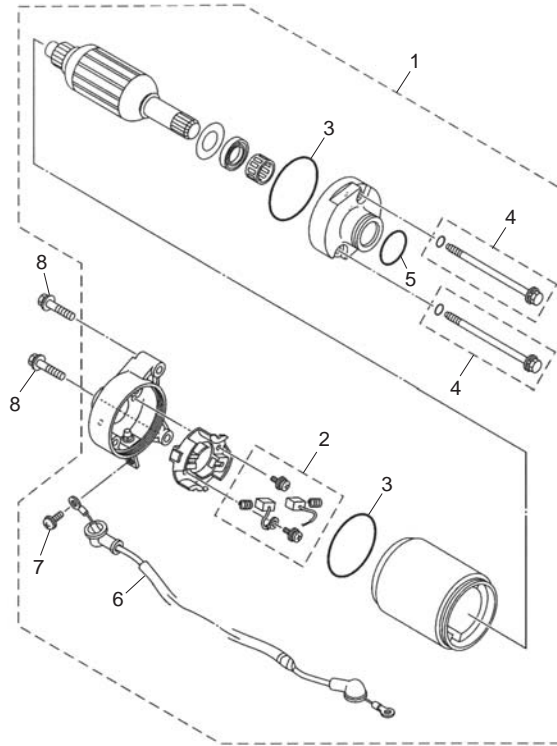

POS.	125	FRANÇAIS	ENGLISH	ESPAÑOL
1	Y984	DEMARREUR COMPLET	STARTING MOTOR ASSY	MOTOR ARRANQUE COMPLETO
2	Y985	CHARBON	BRUSH SET	JUEGO DE ESCOBILLAS
3	Y755	JOINT TORIQUE	O-RING	ANILLO TÓRICO
4	Y987	VIS	BOLT	TORNILLO
5	Y988	JOINT TORIQUE	O-RING	ANILLO TÓRICO
6	Y989	CABLE ÉLECTRIQUE	ELECTRIC WIRE ASS	CABLE COMPLETO
7	Y990	VIS	SCREW	TORNILLO
8	Y991	VIS	SCREW	TORNILLO

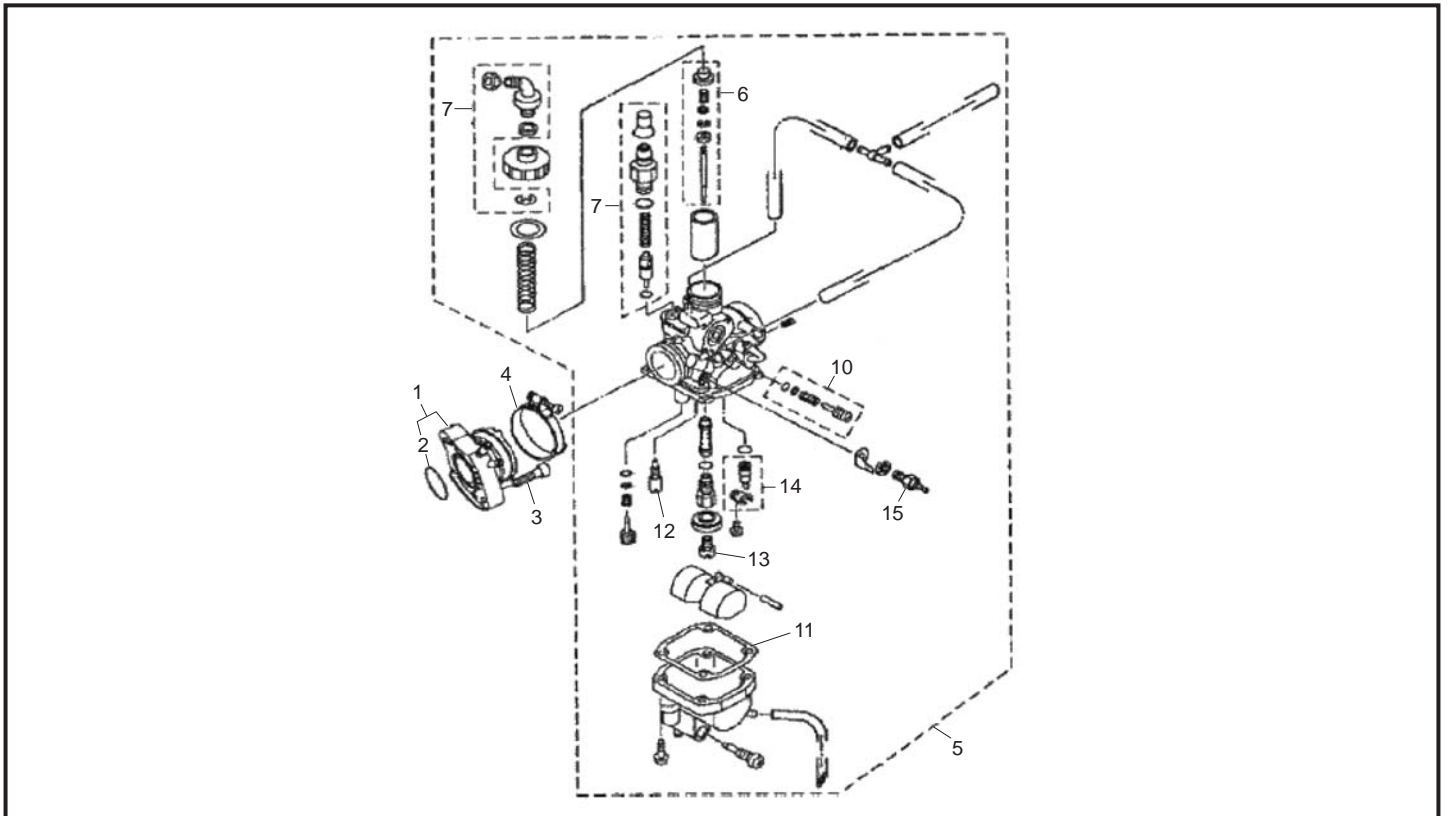
Carburateur / Carburator / Carburador

POS.	125	FRANÇAIS	ENGLISH	ESPAÑOL
1	Y969	PIPE D'ADMISSION	INTAKE MANIFOLD	TOBERA DE CARBURADOR
2	Y970	JOINT TORIQUE	O-RING	ANILLO TÓRICO
3	Y971	VIS	SCREW	TORNILLO
4	Y972	COLLIER	HOSE CLAMP ASST	BRIDA TOBERA
5	Y973	CARBURATEUR COMPLET	CARBURATOR ASSY	CARBURADOR COMPLETO
6	Y974	KIT AIGUILLE	NEEDLE SET	CONJUNTO AGUJA
7	Y975	KIT REGLAGE CABLE	CABLE ADJUST SCREW SET	CONJUNTO TORNILLO TENSOR CABLE
8	Y976	JOINT	GASKET	JUNTA
9	Y177	KIT STARTER	STARTER SET	ESTÁRTER
10	Y595	KIT VIS DE RALENTI	THROTTLE SCREW SET	CONJUNTO TORNILLO DEL RALENTÍ
11	Y661	JOINT DE CUVE	GASKET FLOAT CHAMBER	JUNTA DE LA CUBA
12	Y978	GICLEUR DE RELANTI (15)	JET PILOT (15)	SURTIDOR DE RALENTÍ BAJA (15)
13	Y979	GICLEUR PRINCIPAL (95)	JET PILOT (95)	SURTIDOR PRINCIPAL (95)
14	Y980	KIT POINTEAU	NEEDLE VALVE SET	CONJUNTO VÁLVULA DE AGUJA
15	Y981	RECHAUFFEUR COMPLET	HEATER ASSY	RECALENTAMIENTO



created by: www.clandisseny.com

SHERCO

www.sherco-moto.com

2009

SKF



MICHELIN

Leonelli
IMPIANTI DI ACCENSIONE IGNITION SYSTEMS

MINERVA OIL

SHERCO
Motorcycles